

# Image Compression and Watermarking

Image Processing

CSE 166

Lecture 13

# Announcements

- Assignment 5 is due May 16, 11:59 PM
- Assignment 6 will be released May 16
  - Due May 23, 11:59 PM
- Reading
  - Chapter 8: Image Compression and Watermarking
    - Sections 8.1, 8.9, 8.10, and 8.12

# Data compression

- Data redundancy

$$R = 1 - \frac{1}{C}$$

where compression ratio

$$C = \frac{b}{b'}$$

where

$b$  and  $b'$  are the number of bits in two different representations of the same information

# Data redundancy in images

Coding  
redundancy



Does not need all  
8 bits

Spatial  
redundancy

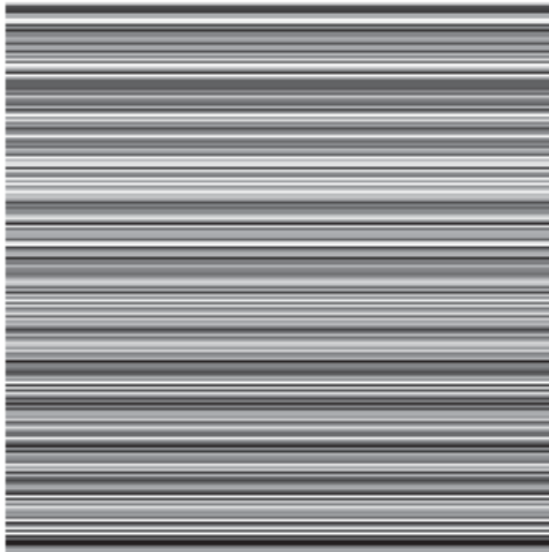

Information is  
unnecessarily  
replicated

Irrelevant  
information



Information is  
not useful

# Image information

- Entropy

$$\tilde{H} = - \sum_{k=0}^{L-1} p_r(r_k) \log_2(p_r(r_k))$$

where

$L$  is the number of intensity or gray levels

$r_k$  is input image intensity or gray level value  $k$

$p_r(r_k)$  is normalized histogram of input image

– It is not possible to encode input image with fewer than  $\tilde{H}$  bits/pixel

# Fidelity criteria, objective (quantitative)

- Total error

$$\sum_{x=0}^{M-1} \sum_{y=0}^{N-1} \left( \hat{f}(x, y) - f(x, y) \right)$$

- Root-mean-square error

$$e_{\text{rms}} = \left( \frac{1}{MN} \sum_{x=0}^{M-1} \sum_{y=0}^{N-1} \left( \hat{f}(x, y) - f(x, y) \right)^2 \right)^{1/2}$$

- Mean-square signal to noise ratio (SNR)

$$\text{SNR}_{\text{ms}} = \frac{\sum_{x=0}^{M-1} \sum_{y=0}^{N-1} \hat{f}(x, y)^2}{\sum_{x=0}^{M-1} \sum_{y=0}^{N-1} \left( \hat{f}(x, y) - f(x, y) \right)^2}$$

# Fidelity criteria, subjective (qualitative)

**TABLE 8.2**  
Rating scale of  
the Television  
Allocations Study  
Organization.  
(Frendendall and  
Behrend.)

Value	Rating	Description
1	Excellent	An image of extremely high quality, as good as you could desire.
2	Fine	An image of high quality, providing enjoyable viewing. Interference is not objectionable.
3	Passable	An image of acceptable quality. Interference is not objectionable.
4	Marginal	An image of poor quality; you wish you could improve it. Interference is somewhat objectionable.
5	Inferior	A very poor image, but you could watch it. Objectionable interference is definitely present.
6	Unusable	An image so bad that you could not watch it.

# Approximations

Objective (quantitative) quality  
rms error (in intensity levels)

5.17

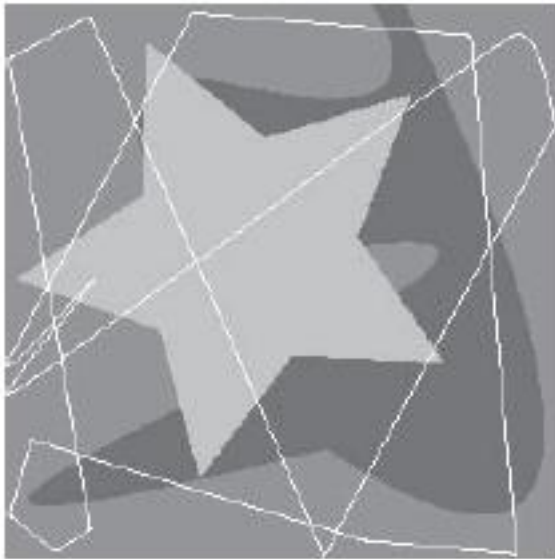

(a)

15.67



(b)

14.17



(c)

Lower is  
better

Subjective (qualitative) quality, relative

(a) is better  
than (b),  
(b) is better  
than (c)



# Compression system

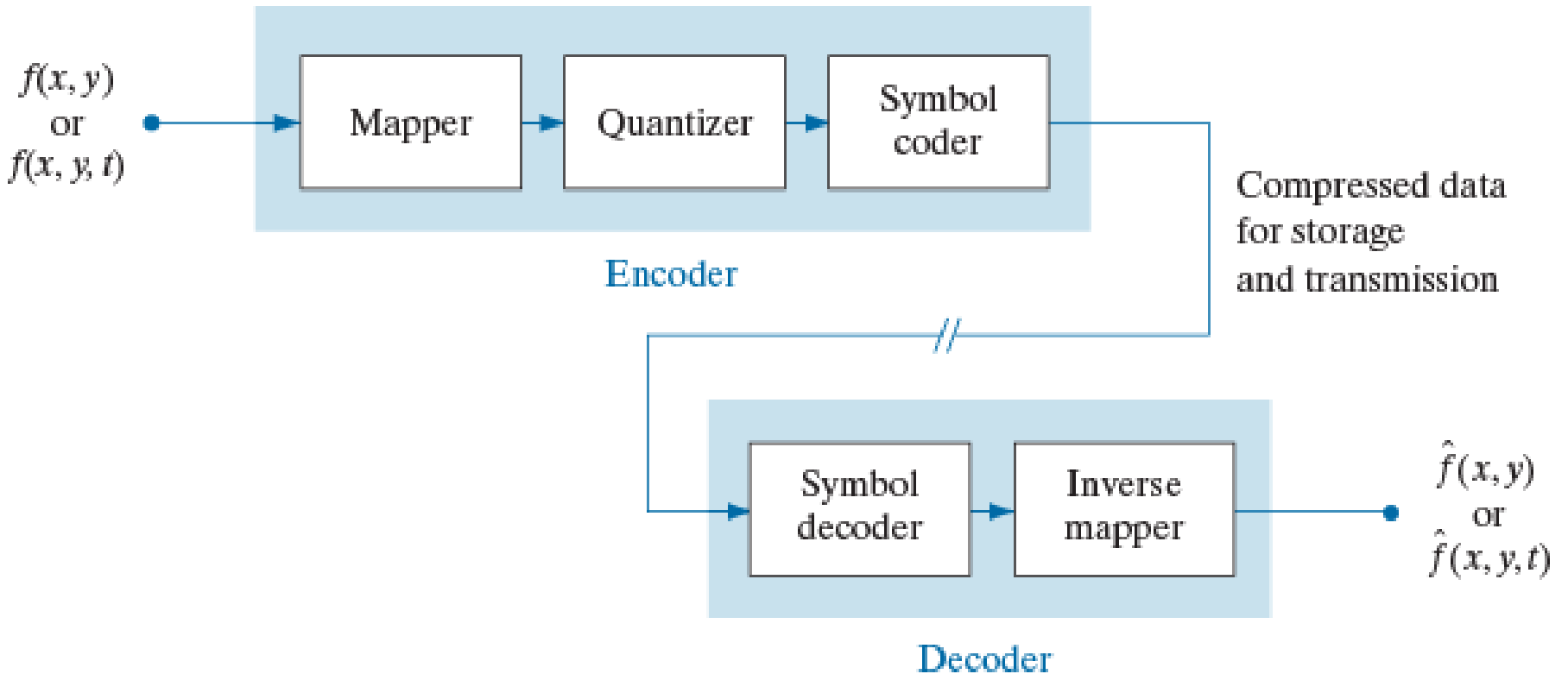

# Compression methods

- Huffman coding
- Golomb coding
- Arithmetic coding
- Lempel-Ziv-Welch (LZW) coding
- Run-length coding
- Symbol-based coding
- Bit-plane coding
- Block transform coding
- Predictive coding
- Wavelet coding

# Symbol-based coding

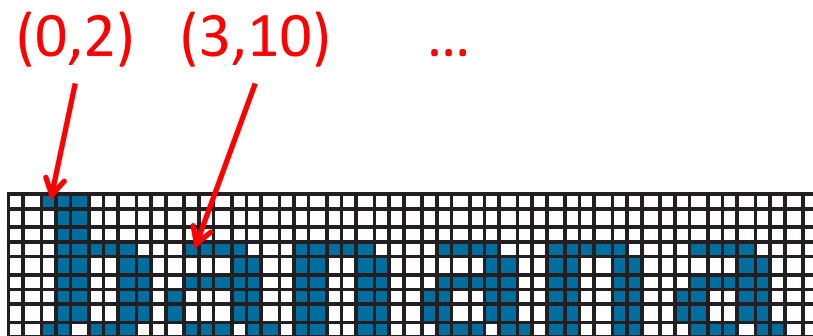

Token	Symbol
0	
1	
2	

Triplet
(0, 2, 0)
(3, 10, 1)
(3, 18, 2)
(3, 26, 1)
(3, 34, 2)
(3, 42, 1)

# Block-transform coding

## Encoder

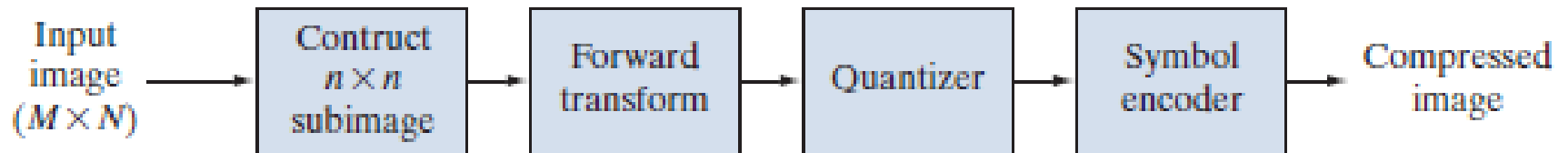

## Decoder

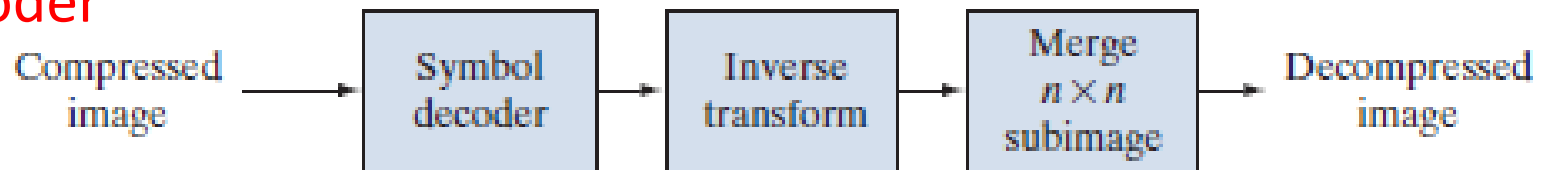

# Block-transform coding

- Example: discrete cosine transform

$n \times n$  subimage  $g(x, y)$

$$T(u, v) = \sum_{x=0}^{n-1} \sum_{y=0}^{n-1} g(x, y) \alpha(u) \alpha(v) \cos\left(\frac{(2x+1)u\pi}{2n}\right) \cos\left(\frac{(2y+1)v\pi}{2n}\right)$$

where

$$\alpha(u) = \begin{cases} \sqrt{\frac{1}{n}} & \text{if } u = 0 \\ \sqrt{\frac{2}{n}} & \text{otherwise} \end{cases} \quad \text{and} \quad \alpha(v) = \begin{cases} \sqrt{\frac{1}{n}} & \text{if } v = 0 \\ \sqrt{\frac{2}{n}} & \text{otherwise} \end{cases}$$

- Inverse

$$g(x, y) = \sum_{u=0}^{n-1} \sum_{v=0}^{n-1} T(u, v) \alpha(u) \alpha(v) \cos\left(\frac{(2x+1)u\pi}{2n}\right) \cos\left(\frac{(2y+1)v\pi}{2n}\right)$$

# Block-transform coding

4x4 subimages (4x4 basis images)

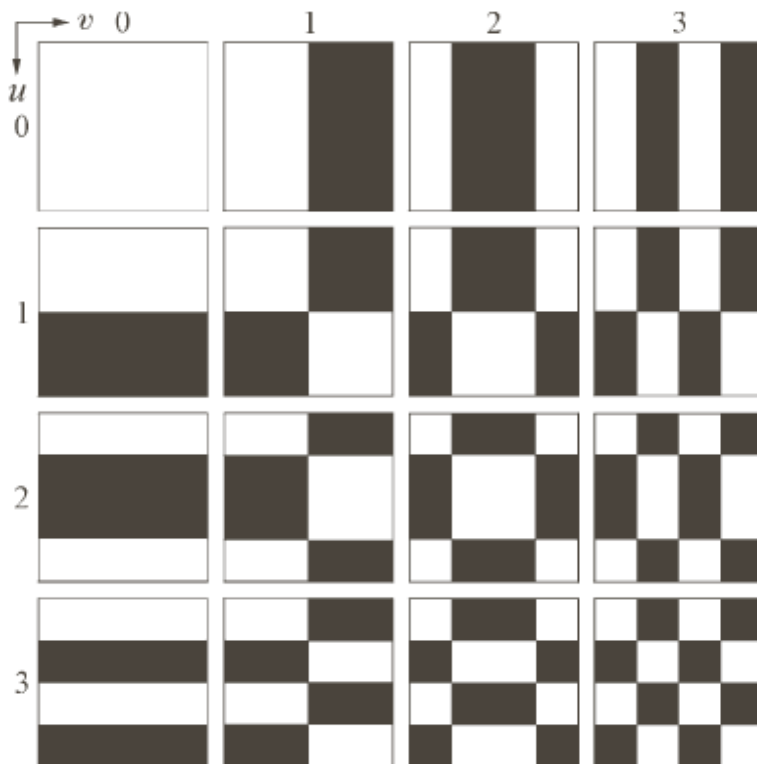

Walsh-Hadamard transform

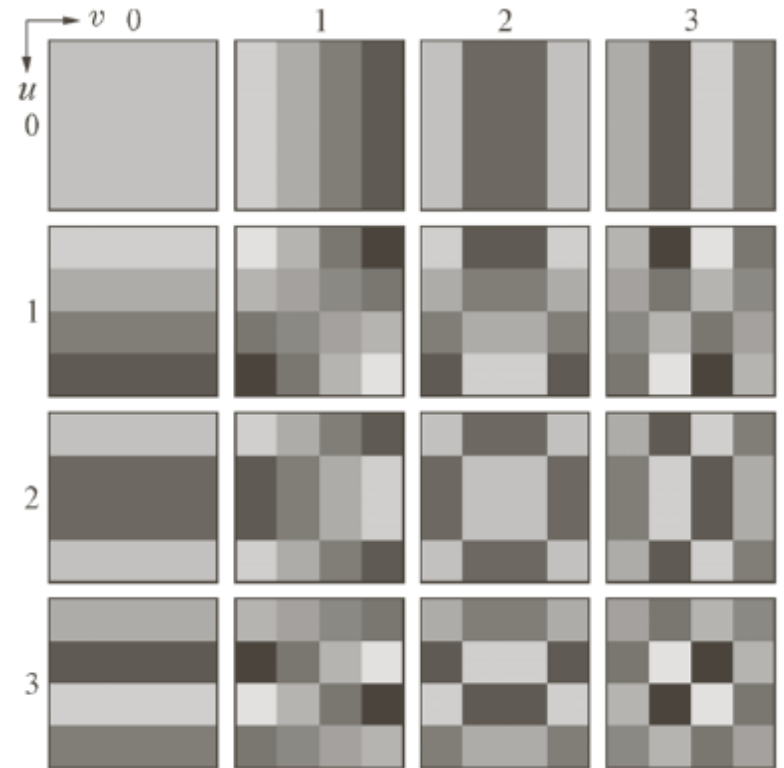

Discrete cosine transform

# Block-transform coding

8x8  
subimages

Fourier  
transform

Walsh-  
Hadamard  
transform

cosine  
transform

Retain 32  
largest  
coefficients



Error image

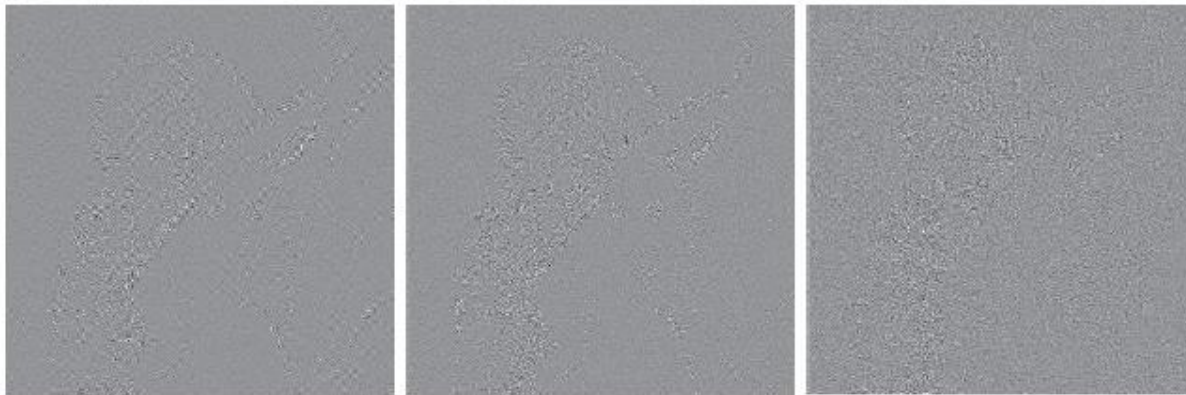

rms error

2.32

1.78

1.13

Lower is  
better

15

# Block-transform coding

Reconstruction error  
versus subimage size

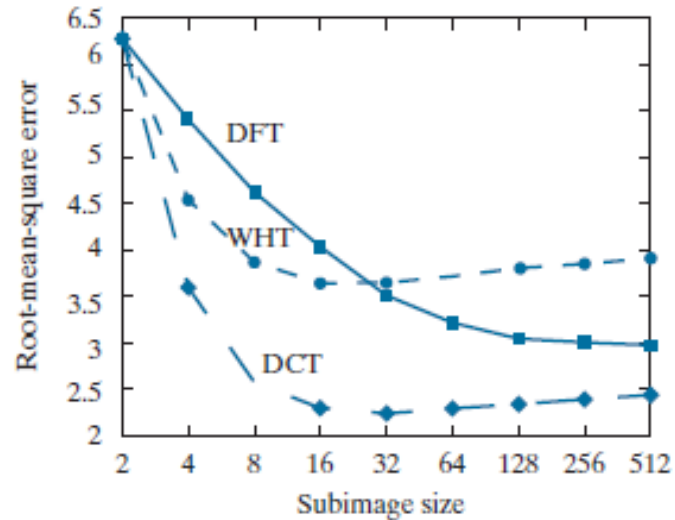

DCT subimage size: 2x2

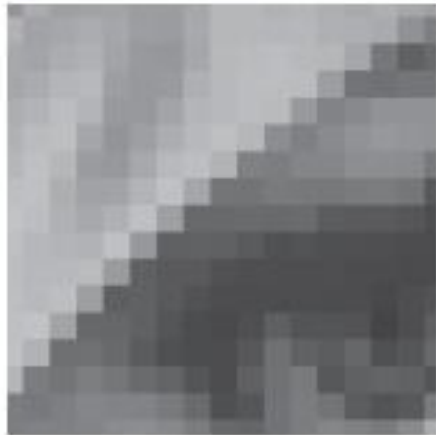

4x4



8x8





# JPEG uses block DCT-based coding

Zoomed

Compression  
reconstruction

Scaled error  
image

compression  
reconstruction

25:1

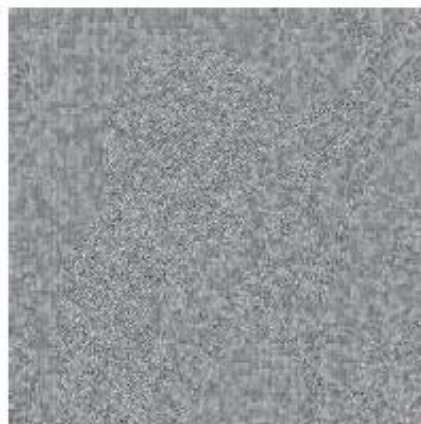
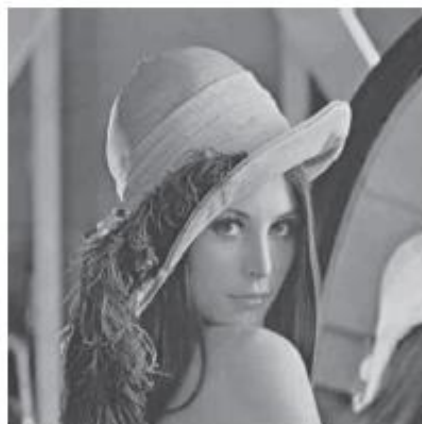

Compression  
ratio

52:1

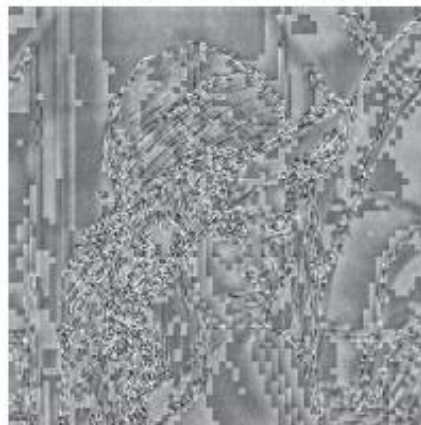

# Predictive coding model

## Encoder

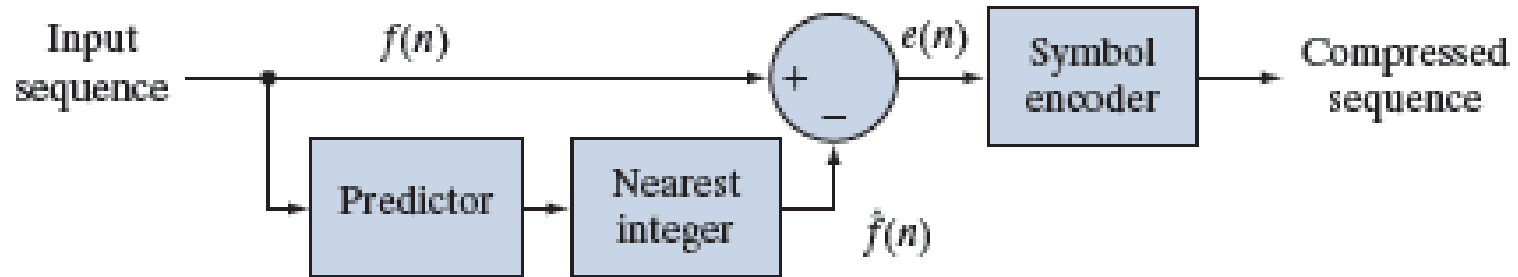

## Decoder

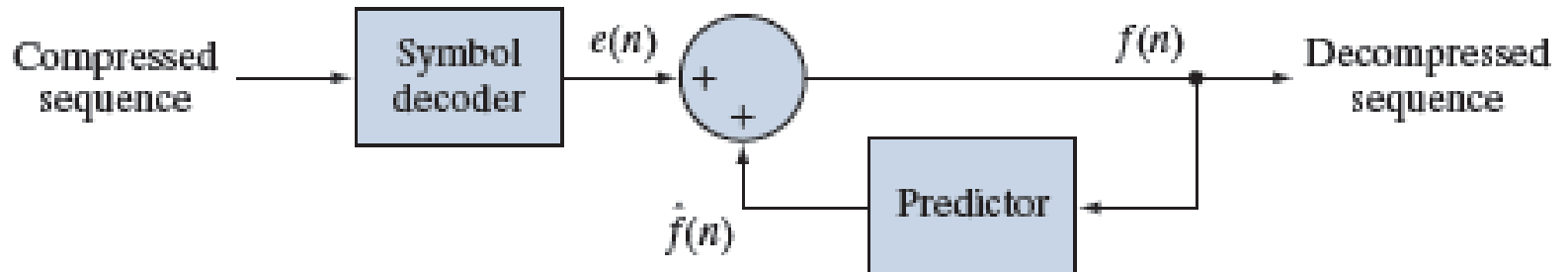

# Predictive coding

Example: previous pixel coding

Input image

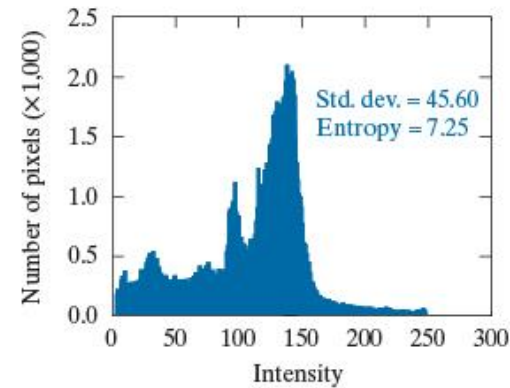
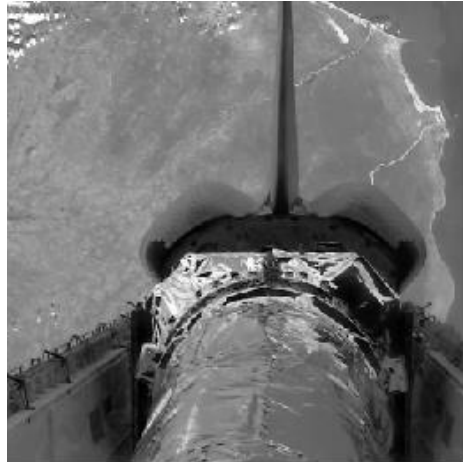

Prediction error image

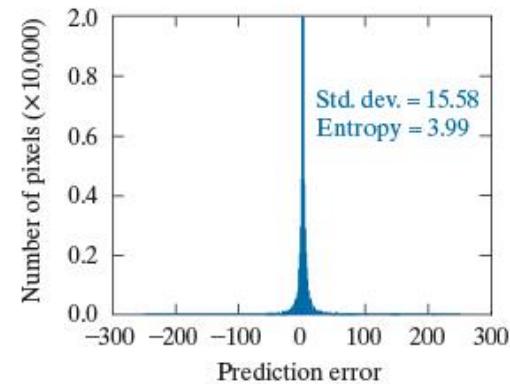
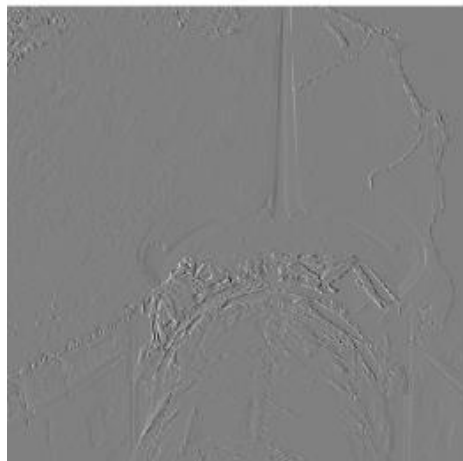

Histograms

# Wavelet coding

## Encoder



## Decoder



# Wavelet coding

Detail coefficients below 25 are truncated to zero

**TABLE 8.15**

Decomposition level impact on wavelet coding the  $512 \times 512$  image of Fig. 8.9(a).

Decomposition Level (Scales or Filter Bank Iterations)	Approximation Coefficient Image	Truncated Coefficients (%)	Reconstruction Error (rms)
1	$256 \times 256$	74.7%	3.27
2	$128 \times 128$	91.7%	4.23
3	$64 \times 64$	95.1%	4.54
4	$32 \times 32$	95.6%	4.61
5	$16 \times 16$	95.5%	4.63

# JPEG-2000 uses wavelet-based coding

Compression  
reconstruction

Scaled error  
image

Zoomed  
compression  
reconstruction

25:1

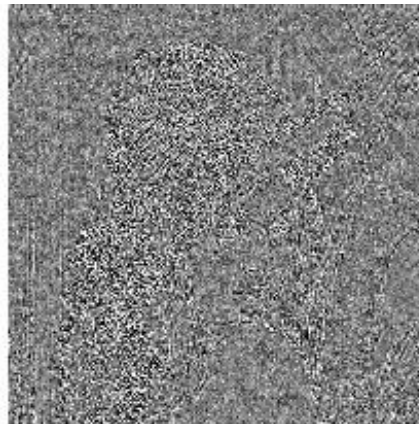

Compression  
ratio

52:1

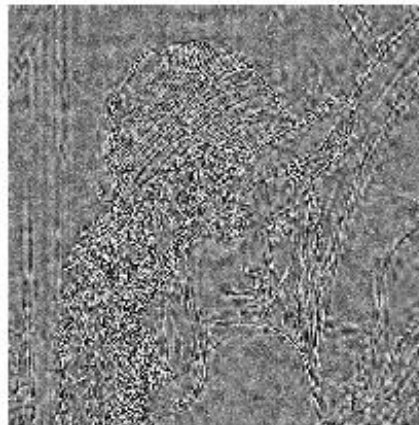

# JPEG-2000 uses wavelet-based coding

Compression  
reconstruction

Scaled error  
image

Zoomed  
compression  
reconstruction

75:1

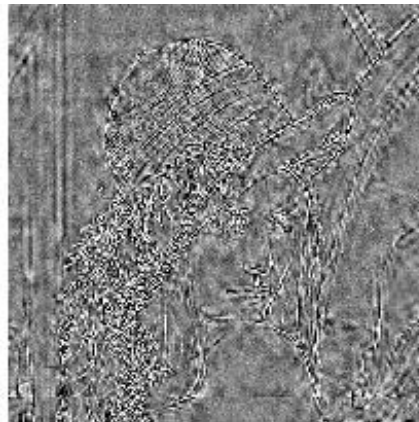

Compression  
ratio

105:1

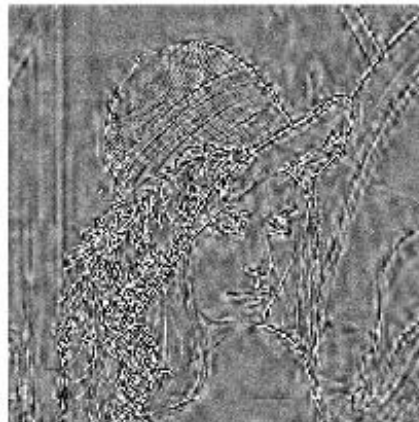

# Image watermarking

- Visible watermarks
- Invisible watermarks



# Visible watermark



Watermark



Watermarked  
image



Original image  
minus watermark

$$f_w = (1 - \alpha)f + \alpha w$$

# Invisible image watermarking system

## Encoder

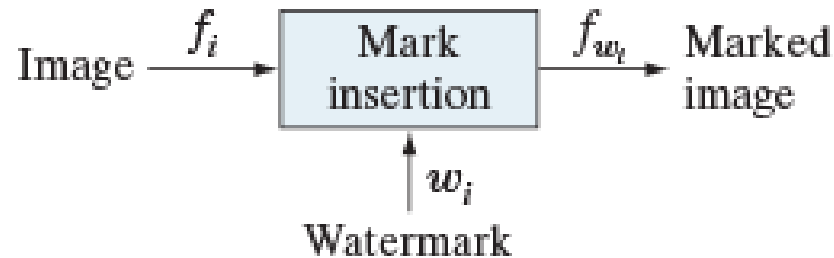

## Decoder

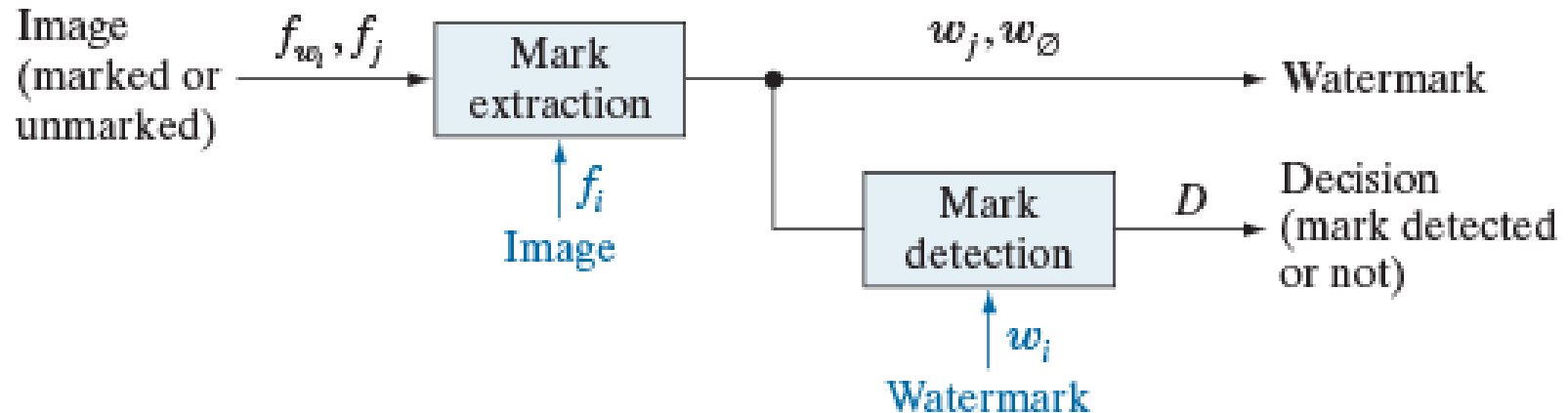

# Invisible watermark

Example: watermarking using two least significant bits

Original image



Extracted watermark



Two least significant bits

JPEG compressed

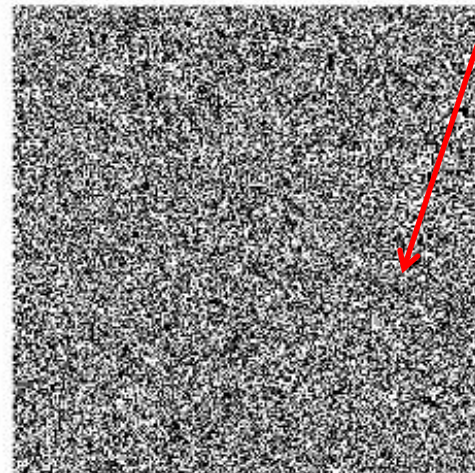

Fragile invisible watermark

# Invisible watermark

Example: DCT-based watermarking

Watermarked  
images  
(different  
watermarks)

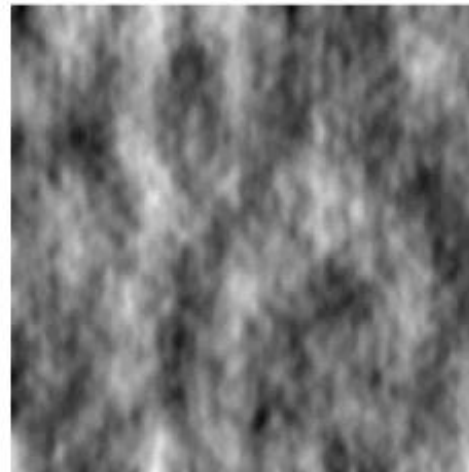
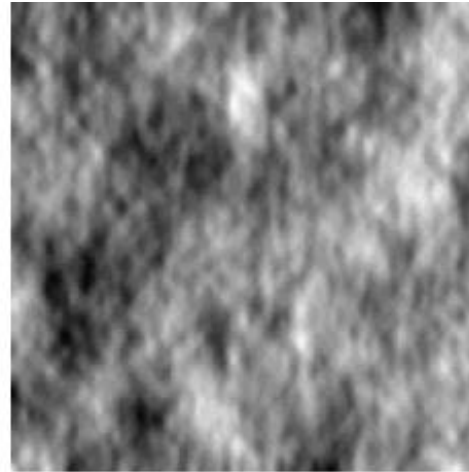

Extracted  
robust  
invisible  
watermark

# Next Lecture

- Morphological image processing
- Reading
  - Chapter 9: Morphological image processing
    - Sections 9.1, 9.2, 9.3, and 9.5 (through subsection connected components)