

Implementing Line-rate Services for Gigabit Networks with the the NetFPGA



Monday, February 9, 2008

John W. Lockwood

Stanford University

<http://stanford.edu/~jwlockwd/>

jwlockwd@stanford.edu







Hardware and tools available for university programs thanks to grants, donations, and/or partnerships from:

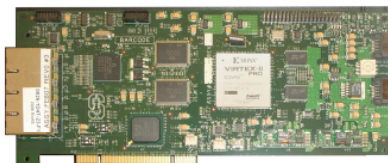

What can the NetFPGA do?

A line-rate, flexible, open networking platform used for network research and in classroom experimentation.



-  [Network Interface Card](#)
-  [Hardware Accelerated Linux Router](#)
-  [IPv4 Reference Router](#)
-  [Traffic Generator](#)
-  [Openflow Switch](#)
-  [List of All Projects](#)
-  [Add Your Project](#)

Who, Where, Why

Who uses the NetFPGA?

- Teachers & students
- Researchers

Where are NetFPGAs?

- 1,000 cards worldwide
- 500 registered users
- 120 Institutions
- 17 Countries



Why use the NetFPGA

- Offload processing from CPU to FPGA on NIC
- Teach students how to build a real Internet Router
- Add features to an Internet Router
- Precisely Measure Internet systems
- Prototype entirely new networking systems



The Internet is Staggering Success

• Society is Well Connected

- Email (Everyone is reachable)
- Web 1.0 (Websites, search engines)
- Web 2.0 (Interactive, User-generated content)
 - Google Apps, Facebook, ...

• Systems Interoperate

- Everything over IP (Video, Voice, CATV, ..)
- IP over Everything (Ethernet, Wi-Fi, EVDO, ..)

• Electronic Commerce Flourishes

- Shopping carts, iTunes



But Today's Internet Now Fails Us (1/2)

- **Denial of Service Attacks**
 - Websites are shut down by coordinated attacks
- **Worms and Viruses infect our PCs**
 - Our computers are attacked on a daily basis
 - Networks can help confine damage

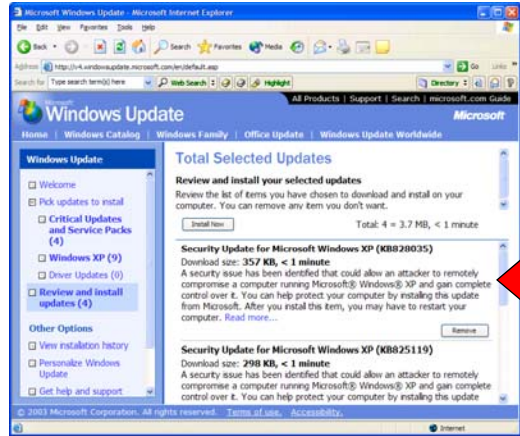

But Today's Internet Now Fails Us (2/2)

- **Phishing**
 - We don't know who to trust
- **Identity Theft**
 - Others don't know if we are ourselves
- **e-Companies are concerned**



The Internet needs an overhaul

- **Networks need to be secure**
 - Verify credentials of users, hosts, servers, ..
- **Routers transport more types of traffic**
 - Support best effort (still), but also allocate bandwidth for: Voice, Video, and real-time apps
- **Users want value-added services in the net**
 - Network Security
 - Quality of Service
 - Reliable Communications



The NetFPGA

Networking
Software
running on a
standard PC

A hardware
accelerator
built with Field
Programmable
Gate Array
driving Gigabit
network links

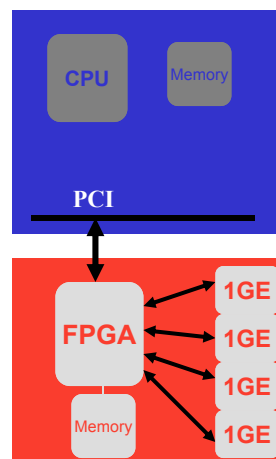

PC with NetFPGA



NetFPGA Board



An IP Router on NetFPGA

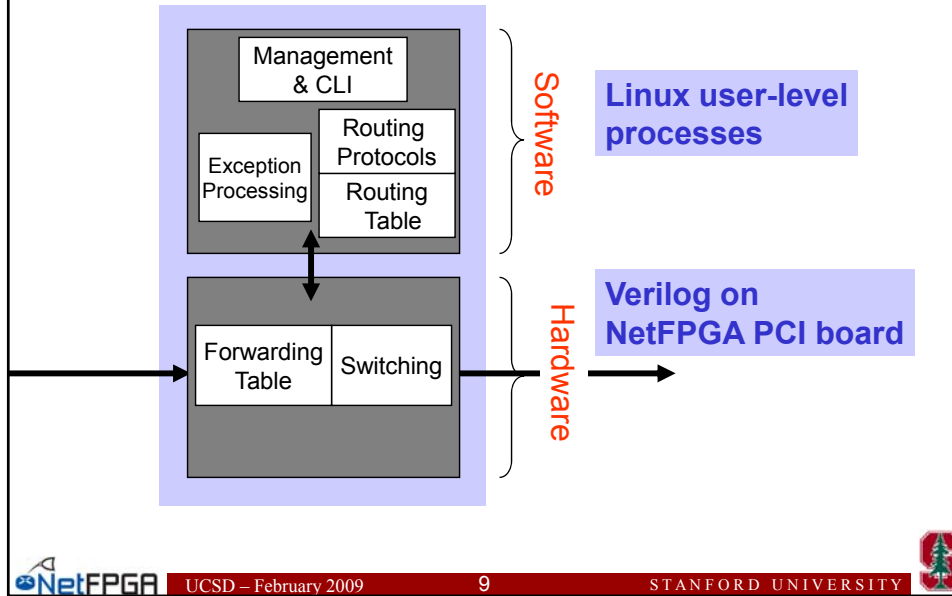

Generic Datapath Architecture

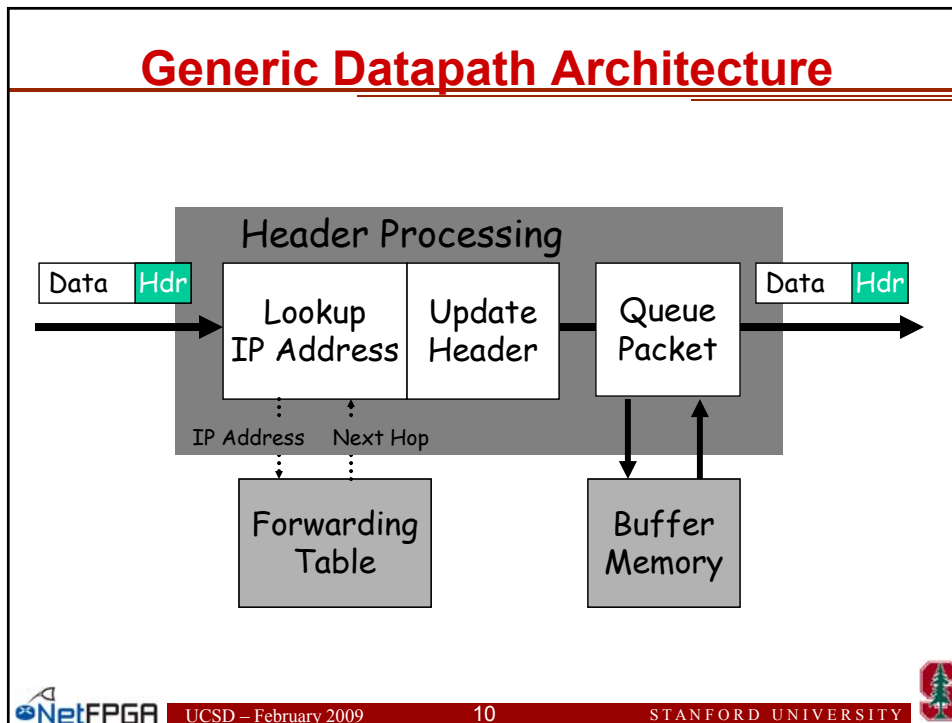

Usage #1

Running the Router Kit

User-space development, 4x1GE line-rate forwarding

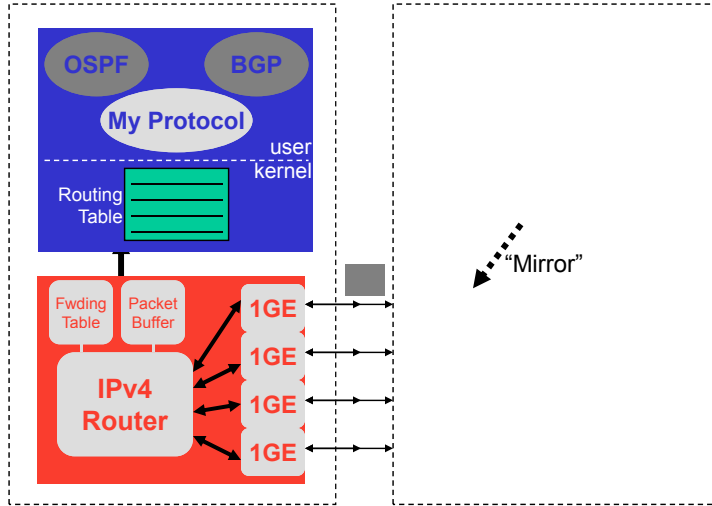

Usage #2

Building Modular Router Modules

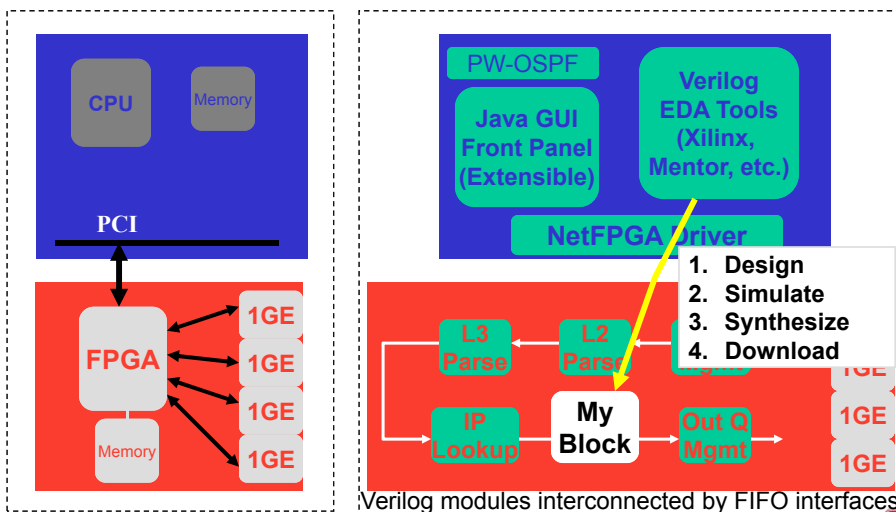

Router Pipeline Stages

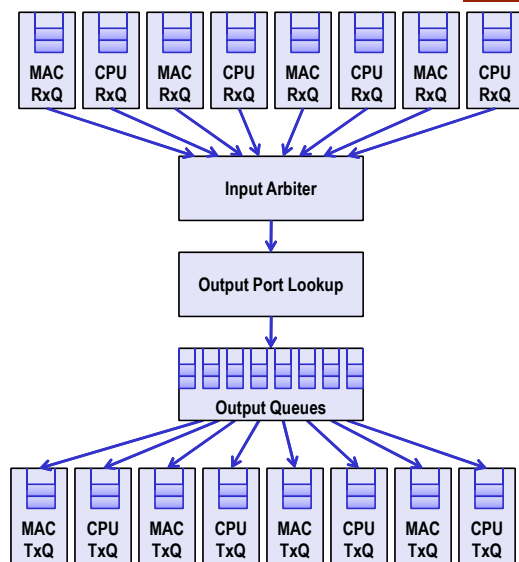

Inter-module Communication

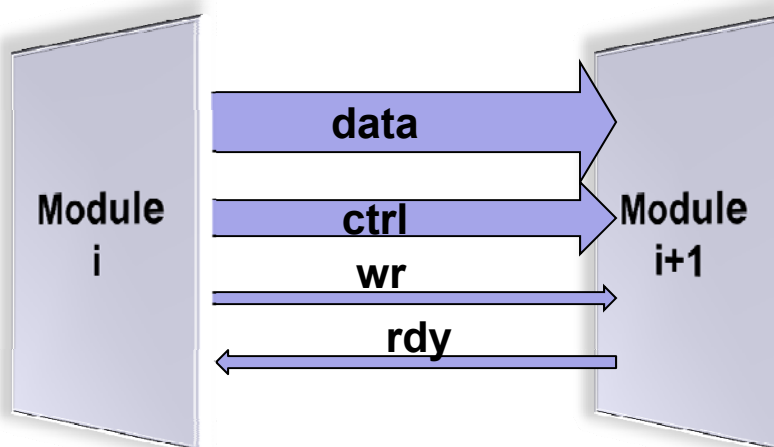

Creating new systems

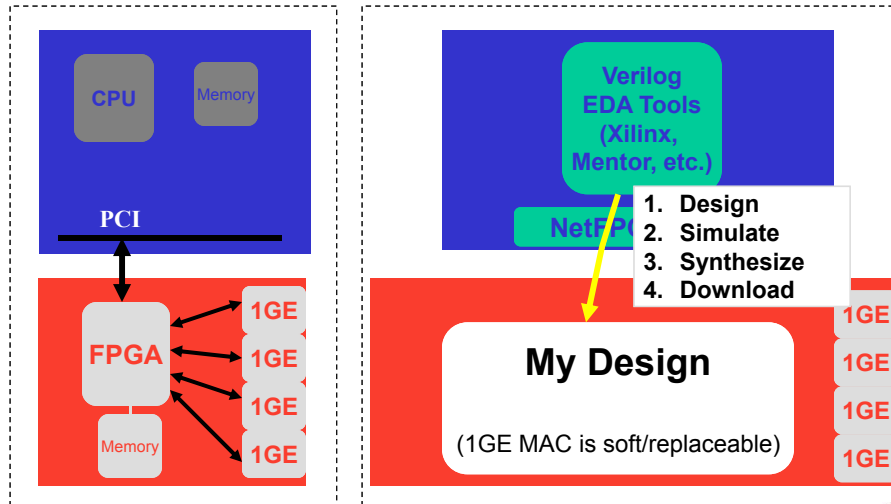

Building the NetFPGA route from the Verilog Source Code

Using the Xilinx ISE tools to
synthesize the logic for the FPGA



Building the NetFPGA Router

The image shows three terminal windows. The top window is titled 'root@nf-test9:~/NF2/projects/tutorial_router/synth' and shows the command 'make' being executed. The middle window is titled 'root@nf-test9:~/NF2/projects/tutorial_router/sw' and shows the command './tut_router_gui.pl' being executed. The bottom window is titled 'jnaous@jadsdesktop:~/Desktop - Shell - Konsole' and shows the output of a 'ping 192.168.17.1' command, including the IP address, TTL, and response times for six consecutive pings.

```
root@nf-test9:~/NF2/projects/tutorial_router/synth
File Edit View Terminal Tabs Help
[root@nf-test9 ~]# cd NF2/projects/tutorial_router/synth/
[root@nf-test9 synth]# make

root@nf-test9:~/NF2/projects/tutorial_router/sw
File Edit View Terminal Tabs Help
[root@nf-test9 ~]# cd NF2/projects/tutorial_router/sw/
[root@nf-test9 sw]# ./tut_router_gui.pl

jnaous@jadsdesktop:~/Desktop - Shell - Konsole
Session Edit View Bookmarks Settings Help

jnaous@jadsdesktop:~/Desktop> ping 192.168.17.1
PING 192.168.17.1 (192.168.17.1) 56(84) bytes of data:
64 bytes from 192.168.17.1: icmp_seq=1 ttl=64 time=0.047 ms
64 bytes from 192.168.17.1: icmp_seq=2 ttl=64 time=0.038 ms
64 bytes from 192.168.17.1: icmp_seq=3 ttl=64 time=0.038 ms
64 bytes from 192.168.17.1: icmp_seq=4 ttl=64 time=0.044 ms
64 bytes from 192.168.17.1: icmp_seq=5 ttl=64 time=0.040 ms
64 bytes from 192.168.17.1: icmp_seq=6 ttl=64 time=0.036 ms
```



Explore the Router

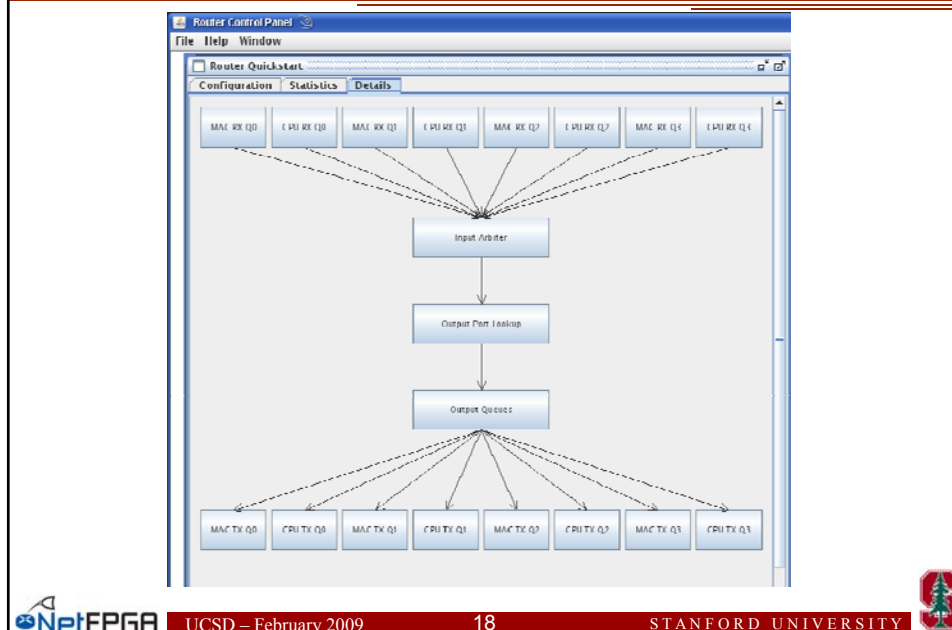

Look inside the Router

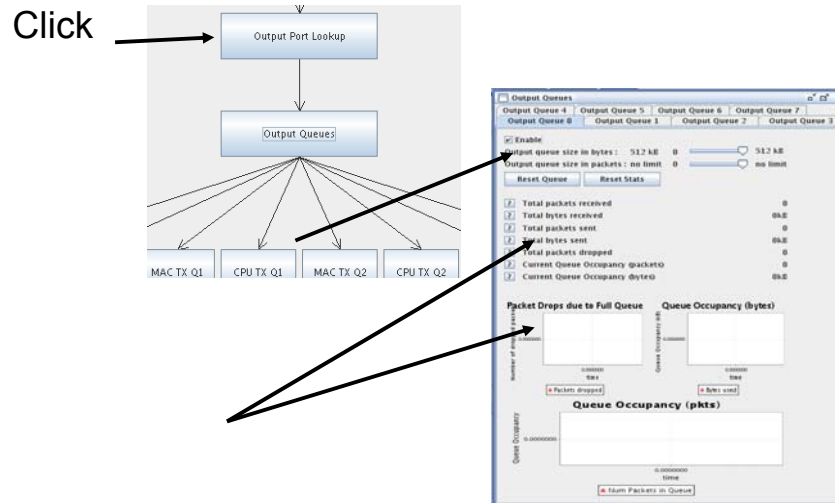

Networked FPGAs in Research

- 1. Managed flow-table switch**
 - <http://OpenFlowSwitch.org/>
- 2. Buffer Sizing**
 - Reduce buffer size & measure buffer occupancy.
- 3. RCP: Congestion control**
 - New module for parsing and overwriting new packet
 - New software to calculate explicit rates
- 4. Deep Packet Inspection (FPX)**
 - TCP/IP Flow Reconstruction
 - Regular Expression Matching
 - Bloom Filters
- 5. Packet Monitoring (ICSI)**
 - Network Shunt
- 6. Precise Time Protocol (PTP)**
 - Synchronization among Routers



Photos from NetFPGA Tutorials



SIGCOMM - Seattle, Washington, USA



Beijing, China



SIGMETRICS - San Diego, California, USA



Bangalore, India



EuroSys - Glasgow, Scotland, U.K.

<http://netfpga.org/pastevents.php> and <http://netfpga.org/upcomingevents.php>



NetFPGAs in the Internet 2 & Japan

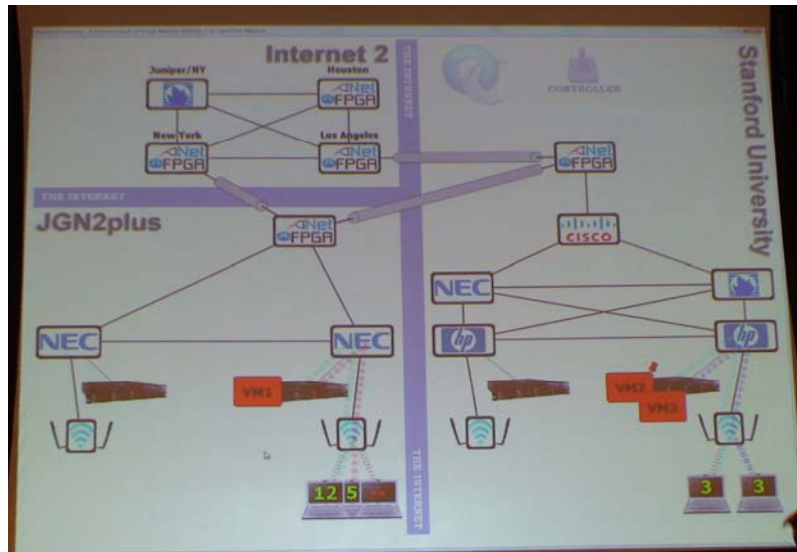

From GENI Engineering Conference - Oct 2008



NetFPGA Cube Development Systems

- **PCs assembled from parts**
 - Stanford University
 - Cambridge University
- **Pre-built systems available**
 - Accent Technology Inc
- **Details are in the Guide**

<http://netfpga.org/static/guide.html>



Rackmount NetFPGA Servers



2U Server
(Dell 2950)



NetFPGA inserts in
PCI or PCI-X slot



1U Server
(Accent Technology, Inc)



Stanford NetFPGA Cluster

Stanford NetFPGA Cluster (NFC)

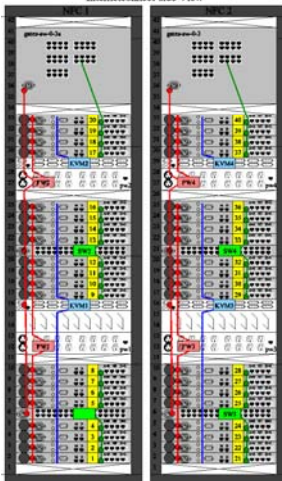

Statistics

- Rack of 40
 - 1U PCs
 - NetFPGAs
- Manged
 - Power,
 - Console
 - VLANs
- Provides 160 Gbps of full line-rate processing bandwidth



NetFPGA 2008 Summe rCamp

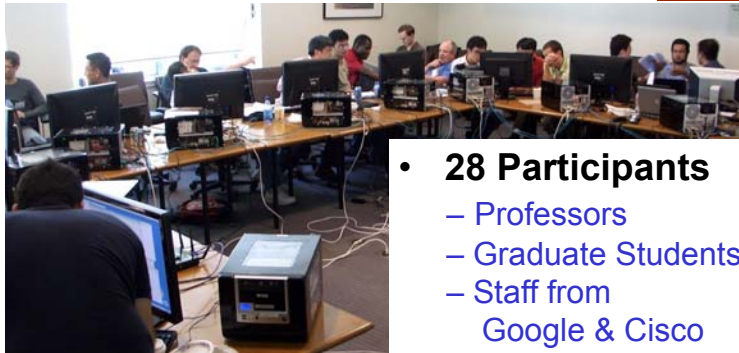

- **28 Participants**
 - Professors
 - Graduate Students
 - Staff from Google & Cisco
- **Format : One week event at Stanford**
 - 2.5 Days of Training on the reference router
 - 2 Days to work on projects
 - Final Projects presented on Friday Afternoon
- **Sample project: Wire-speed traffic distributor**



NetFPGA 2009 Developer's Workshop

- **Goal**
 - Present and demonstrate new projects
- **Format**
 - Workshop Paper and Live Demonstration
- **Dates & Location**
 - Date: August 13-14, 2009 (this summer)
 - Location: Stanford University
- **Submissions Due**
 - April 10, 2009
- **Details**
 - <http://netfpga.org/wordpress/?p=269>



Need Help? – See Discussion Forums

NetFPGA Forum

User Name User Name Remember Me?
Password

[Register](#) [FAQ](#) [Members List](#) [Calendar](#) [Today's Posts](#) [Search](#)

Welcome to the NetFPGA Forum.

If this is your first visit, be sure to check out the [FAQ](#) by clicking the link above. You may have to [register](#) before you can post: click the register link above to proceed. To start viewing messages, select the forum that you want to visit from the selection below.

Forum	Last Post	Threads	Posts
General NetFPGA discussion A forum dedicated to general NetFPGA discussion, including installation, setup and usage.			
General Discussion General discussion forum about the NetFPGA platform	computer freezes when I... by sumeet23 02-06-2009 10:49 PM	54	209
Installation and Setup (3 Viewing) This forum should be used for discussion of installation and setup of the NetFPGA system.	"download failed" when... by Abhishek 02-07-2009 12:05 AM	39	179
Forum requests/queries Forum to request new forums/query existing forums.	Increase the flexibility in... by gaci 01-12-2009 06:57 PM	2	3
Projects Forums dedicated to specific NetFPGA projects			
Packet Generator Discussions related to the packet generator	Feature requests by grr 01-16-2009 09:56 PM	7	34



NetFPGA Hardware in North America

Locations of Deployed NetFPGA Hardware

USA - Jan 2009



NetFPGA Hardware in Europe

Locations of Deployed NetFPGA Hardware

EU - Jan 2009



NetFPGA Hardware in Asia

Locations of Deployed NetFPGA Hardware



Acknowledgements

Support for the NetFPGA project has been provided by the following companies and institutions



Disclaimer: Any opinions, findings, conclusions, or recommendations expressed in this material do not necessarily reflect the views of the National Science Foundation or of any other sponsors supporting this project.

Learn more About the NetFPGA

<http://NetFPGA.org/>

-Or-

Google: “NetFPGA”



Learn More

Project summary,
videos, publications,
tutorials



Get Started

Obtain NetFPGA
hardware, download
gateway & software,
review reference
designs



Develop

Create user account,
contribute your code,
document your
project

