

Implementation of the Alamouti OSTBC to a Distributed Set of Single-Antenna Wireless Nodes

Richard E. Cagley
Brad T. Weals
and Scott A. McNally
Toyon Research Corp.
6800 Cortona Drive
Goleta, CA 93117
E-mail: rcagley@toyon.com

Ronald A. Iltis
Shahnam Mirzaei
and Ryan Kastner
University of California
Santa Barbara, CA 93106-9560

Abstract— We consider a system architecture whereby orthogonal space time block codes (OSTBCs) are applied to a distributed set of wireless nodes. The utility offered is that by employing diversity we are able to greatly reduce the necessary link margin usually required to combat fast fading. A distributed set of wireless nodes are particularly well suited for this task as they are typically separated with significant inter-node distance thus having highly uncorrelated channels to a collector. In a typical application, a wireless sensor network (WSN) will have nodes that may wish to transmit data to a possibly mobile stand-off collection point. In this paper, we discuss many practical aspects necessary for a real-world implementation including time and frequency offset estimation as well as channel tracking. As the waveform has been targeted to field programmable gate array (FPGA) hardware, we look at the relative implementation complexity of each signal processing element.

With their use for an increasing number of applications, wireless sensor nodes are being asked to communicate in ever more difficult operational environments. Moving from rather simple installations, such as utility monitoring, wireless sensor networks are being deployed to remote locations and with a range of placement densities. This has meant that WSNs must be able to handle a range of data statistics, from simple environmental readings to high-rate video. And, they may have to perform in networks that include only a few nodes to those that number in the thousands. Finally, the relative placement of nodes may be tens of meters to several kilometers. In this paper we address the specific problem of range extension of wireless sensor nodes that may have to communicate to a remote collection center. Due to the significant range, such sensors do not have line-of-sight to the collector and, furthermore, the collector may be mobile; this results in fast fading [1]. Our approach to this problem is to have the sensors operate cooperatively by collectively transmitting an OSTBC [2], [3], [4].

Over the last decade there has been tremendous growth in the theoretical understanding of information theoretic capacity as it applies to multiple antenna arrays. Ground breaking work has led to practical algorithms that have been shown to dramatically increase not only the spectral efficiency but also the diversity of wireless links [5]. For the proposed application of WSNs we assume that the network is not

spectrally constrained. That is, data statistics are such that there is not a need to perform continuous data transmission and hence there is no need to increase spectral efficiency. Instead, the main problem is to increase transmission range. In particular, we consider embedded wireless sensor equipment, which typically has a limited transmit power. Other authors have proposed techniques whereby multiple sensor nodes can be configured into a virtual antenna array (VAA) in order to accomplish specific objectives. This has included such approaches as collective beamforming [6] and increasing capacity through distributed physical layers [7], [8]. Here, we are only concerned with diversity gains that can help reduce link margins and hence result in a range extension by increasing the reliability of packet delivery.

In order to motivate this concept, we first consider the channel model for our candidate application and illustrate the performance of bit delivery reliability as a function of the number of sensor nodes (antennas). We consider an operational environment where sensor nodes must communicate at a range of hundreds to potentially thousands of meters. In addition, the nodes are likely to be close to the ground or embedded within buildings, further enriching the communications channel. Due to target ranges and the fact sensor nodes are typically close to the ground or embedded, the channel is often non line-of-sight (NLOS). In addition, we allow the collection platform to be both stationary, as well as mobile, such as an aircraft or vehicle. We use the well known Jakes' model to simulate time-varying Rayleigh fading channels, which is reflective of our candidate operating environment [1], [9].

In Figure 1 we illustrate the probability of packet success as a function of range for different numbers of sensor nodes. The collector is assumed to have one antenna element. The simulations were performed with a node transmit power of 20 dBm, receiver sensitivity of -105 dBm, a background noise of -114 dBm/MHz, and a free-space loss exponent of 2.8 [10]. We use binary-phase shift-keying (BPSK) modulation at a rate of 500 kbps and a carrier frequency of 1350 MHz with a packet size of one kByte. Finally, the collection platform speed is set at 100 miles/hour. As can be seen in the figure, there is a significant range extension that can be achieved simply by

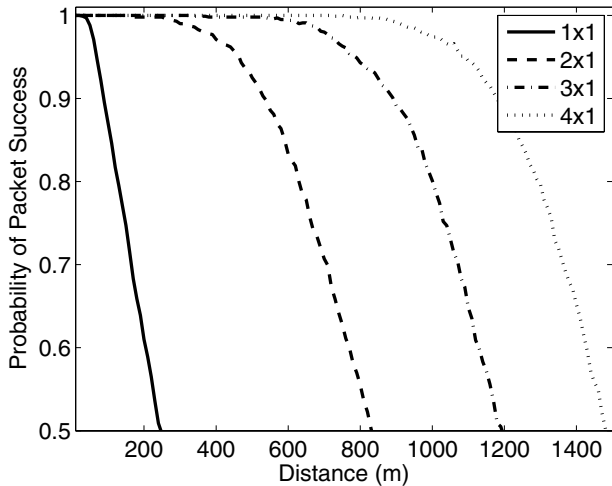

Fig. 1. Probability of packet success as a function of range and number of sensor nodes.

using two transmission nodes (2x1). Additional nodes can be included for an additional extension, with diminishing gains.

The paper is organized as follows. We begin with a discussion of the signal model that is associated with a distributed set of sensors that must form a VAA along with the associated transmission challenges. Next, we discuss the challenging problems of time and frequency offset estimation for such an architecture. We then discuss channel estimation and residual carrier offset correction. Finally, we look at the implementation of the overall architecture onto the FPGA used in Toyon's multiple-input multiple-output (MIMO) transceiver testbed. Finally, we discuss the overall results and future work.

I. SIGNAL MODEL

With N_c antenna elements, the received collector signal $\mathbf{r}_c(t) \in \mathbb{C}^{N_c}$ on the uplink is given in continuous-time by

$$\mathbf{r}_c(t) = \sum_{k=1}^{N_s} \sum_{m=0}^{\infty} \mathbf{h}_k(m) p(t - \tau_k - mT) e^{i\delta\omega_k t} s_k(m) + \mathbf{v}(t), \quad (1)$$

where $\mathbf{h}_k \in \mathbb{C}^{N_c}$ is the channel from sensor k to the collector, E_s is the symbol energy, ω_k is the frequency offset in Hz for sensor k , and τ_k is the corresponding delay. The term $\mathbf{v}(t) = [v_1(t), v_2(t), \dots, v_{N_c}(t)]^T$ represents additive white Gaussian noise with individual terms having variance σ^2 . The symbols $s_k(m)$ represent a training sequence in the estimation phase, or the m -th row and k -th column of an OSTBC matrix [2], [3]. The pulses $p(t)$ are raised-cosine with minimal excess bandwidth to maximize orthogonality. The pulse energy is defined by $2E_s$ where we assume constant node transmit power and hence discard the conventional MIMO normalization; the total transmitted bandpass energy is E_s per information symbol.

This receive signal can be converted to a discrete-time signal by sampling at an oversampling rate with period T_{os} . Assuming N_D samples per symbol period and sampling period

n , the resulting symbol index l is related as $N_D l \equiv n$. The resulting discrete time received signal is

$$\mathbf{r}_c(n) = \sum_{k=1}^{N_s} \sum_{m=0}^{\infty} \mathbf{h}_k(m) q(n - \eta_k - mN_D) e^{i\delta\Omega_k n} s_k(m) + \mathbf{v}(n) \quad (2)$$

where $\eta \equiv \tau/T_{os}$, $\delta\Omega \equiv \delta\omega T_{os}$, and $q(n) = p(nT_{os})$ is the discrete-time sampled pulse shape of $p(t)$. Consider a pulse shape whereby the response on adjacent symbol periods is zero if sampled at the pulse center.

II. TIME AND FREQUENCY OFFSET ESTIMATION

As we consider a distributed set of nodes that will form a virtual antenna array, there are unique synchronization and parameter estimation issues that must be addressed. Figure 2 illustrates these problems associated with having a set of radio frequency (RF) front-end translators that are not colocated on the same platform. In particular, these nodes do not share a common crystal that is used by the frequency synthesizer to create the mixing signals. As such, there will be a relative carrier frequency offset. This will vary from one node to the next and can change over time due to part degradation and temperature variation. In addition, the packets from each of these nodes will not be launched synchronously, unless special considerations are made.

As we consider a packet-based system, the first parameter that must be estimated is the start of the packet. While a simple correlator is an appealing technique, the presence of a potentially large carrier offset precludes its use for all but the shortest training sequences. There are other techniques, such as the generalized successive interference canceller (GSIC), which can be used to estimate the time and carrier offsets of all users, jointly [4]. However, striving for the simplest possible hardware implementation, our approach centers around the homodyne detector.

In order to simplify expressions and improve clarity, here and in the remaining sections, we let $N_c = 1$. Additionally, for this section we will remove the node index k by assuming we are performing parameter estimates for each user individually. In forming the detector, consider a new set of symbols formed by the conjugate pairs of received samples. The individual terms are given by

$$c(n) = r(n)r^*(n - N_D). \quad (3)$$

We note that if sampled at the symbol rate, and aligned with the peak of the pulse shape $q(0)$, the resulting received signal can be simplified to

$$r(n) = e^{i\delta\Omega n} s(n - \eta) + v(n). \quad (4)$$

If proper timing alignment is achieved, the conjugate pair in (3) becomes

$$c(n) = e^{i\delta\Omega N_D} d(n) + \bar{v}(n) \quad (5)$$

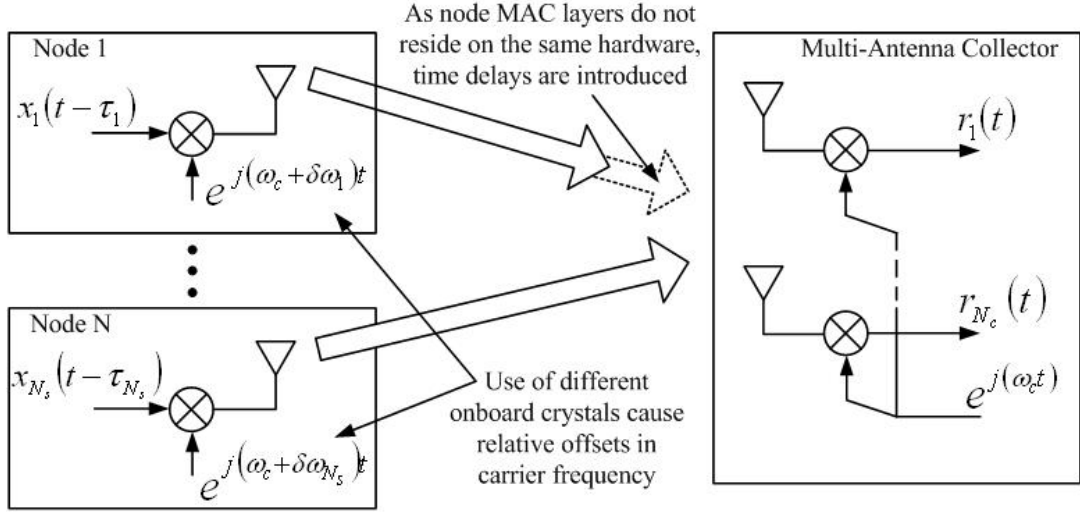

Fig. 2. Parameter estimation for a distributed set of nodes forming a virtual antenna array.

where $d(n) = s(\lfloor (n - \eta)/N_D \rfloor) s^*(\lfloor (n - \eta - 1)/N_D \rfloor)$ are the conjugate pairs of received symbols and $\bar{v}(n) = v(n)v^*(n - N_D)$ is the product of two independent circular Gaussians. We can collect a set of these homodyne symbols corresponding to one less than the length of the training sequence $\mathbf{c}(n) = [c(n), c(n - 1), \dots, c(n - N_{ts} + 2)]^T$. We see that if the symbols $d(n)$ were known then a correlation would result and associated carrier offset formed. For this purpose we create a set of conjugate training symbol pairs $\mathbf{u} = [u_{N_{ts}-1}, \dots, u_2, u_1]^T$ where $u_i \equiv \tilde{s}_{i+1} \tilde{s}_i^*$ and $\{\tilde{s}_i\}$ are a known set of training symbols. Next, a correlation can be formed

$$z(n) = \mathbf{u}^H \mathbf{c}(n). \quad (6)$$

We note there are two sample times of interest. The first is when the correlation symbols and the training period of the transmitted packet are not aligned. In this case, the conjugate sample and symbol pairs will have low correlation and $z(l)$ will result in a low value. However, if the proper offset is encountered the following signal will result

$$z(\eta) = (N_{ts} - 1) E_s e^{i\delta\Omega N_D} + \sum_{m=1}^{N_{ts}-1} u(m) v(m) v^*(m - N_D). \quad (7)$$

We see

$$\bar{z}(\eta) \equiv E[z(\eta)] = (N_{ts} - 1) E_s e^{i\delta\Omega N_D} \quad (8)$$

providing an unbiased estimate of the carrier offset. In addition, we can observe that

$$\sigma_{z(\eta)} \equiv E[(z(\eta) - \bar{z}(\eta))^2] = (N_s - 1) \sigma^4 \quad (9)$$

and the resulting signal to noise ratio (SNR) for the estimate of the carrier offset is

$$\text{SNR} = \frac{(N_{ts} - 1) E_b^2}{(\sigma^2)^2} \quad (10)$$

which we note scales linearly with increasing numbers of training symbols.

III. CHANNEL ESTIMATION AND RESIDUAL CARRIER OFFSET CORRECTION

After timing estimation and associated downsampling, the resulting received signal model is given by

$$y(l) = \mathbf{g}^T(l) \mathbf{s}(l) + v(l) \quad (11)$$

where $\mathbf{g}(l) = [g_1(l), g_2(l), \dots, g_{N_s}(l)]^T$ with individual terms $g_k(l) = h_k(l) e^{j\theta l}$. The term $\theta = \delta\Omega - \delta\hat{\Omega}$ represents the residual carrier offset error. We note there is both a time varying channel ($h_k(l)$), due to mobility, as well as a constant effective Doppler shift ($e^{j\theta l}$) due to inaccuracies in the carrier offset estimation block. In order to track the time-varying channel, there are several possible approaches. One of the highest performers is to employ a Kalman filter (KF) using a second-order autoregressive (AR2) process [11]. However, the use of a Kalman filter, in any form, is prohibitively challenging in terms of hardware implementation for our candidate data rates.

We seek a channel tracker that offers low computational complexity and can be performed recursively. Filters, such as least mean square (LMS), offer this utility while still obtaining good performance [12]. For such a solution we consider the cost

$$J = E \left[\left| y(l) - \hat{\mathbf{g}}^T \mathbf{s}(l) \right|^2 \right] \quad (12)$$

where $\hat{\mathbf{g}}$ is our desired channel estimate. Minimizing this cost we obtain $\hat{\mathbf{g}} = \mathbf{g}$ in the mean, resulting in an unbiased estimate for the channel. Seeking a recursive implementation that can not only estimate the channel with multiple training symbols, but also track the channel in decision-directed (DD) mode, we can form the LMS filter

$$\hat{\mathbf{g}}(l+1) = \hat{\mathbf{g}}(l) + \mu \mathbf{s}^*(l) e(l) \quad (13)$$

where

$$e(l) = [y(l) - \mathbf{s}^T(l) \hat{\mathbf{g}}(l)] \quad (14)$$

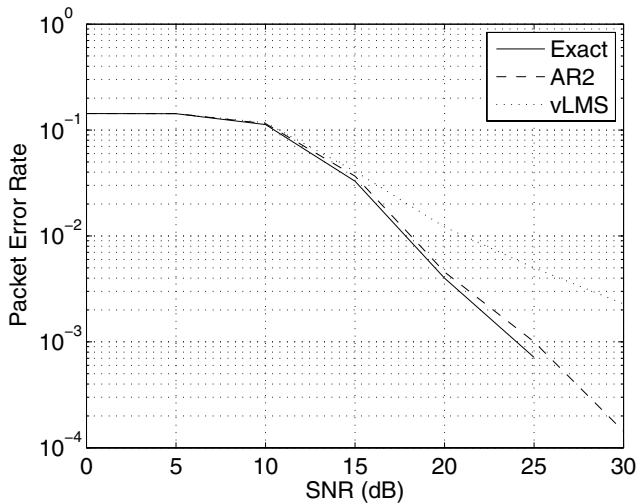

Fig. 3. Packet error rate for a 2x1 OSTBC receiver using different methods of channel estimation.

and μ is the step size.

One of the drawbacks of the classic LMS implementation is the fact that the step size is constant. In most packet-based systems there will be both a training period as well as a data packet period. That is, there will be discrete periods where the LMS filter will be run in both training and DD modes. Intuitively, one solution would be to have different values for μ during each period. But, there is the additional issue that during the first few symbols of the training packet there will be a much larger error than at the end of the training period. For this reason, we employ the variable step-size LMS (vLMS) algorithm proposed by Aboulnasr and Mayyas [13]. Here, the update expression for the step size is given by

$$\mu(l+1) = \alpha\mu(l) + \gamma\text{MSE} \quad (15)$$

where $\text{MSE} = e^*(l)e(l)$ and $\alpha \in \{(0, 1]\}$ and $\gamma > 0$.

In order to verify the performance of the algorithm we consider a 2x1 STC coded system, based on the Alamouti scheme, where we have used different methods to compute the channel estimates. These simulations are based on the same set of operational parameters as those used in Figure 1. The vLMS parameters are $\alpha = .99$ and $\gamma = .001$. Results in Figure 3 show the packet success rate as a function of the signal to noise ratio (SNR). The channels are normalized such that the maximum value of the channel response is equal in magnitude to the transmitted symbol. In the simulations we compare the vLMS architecture to the AR2-KF channel tracker as well as the case where the channel is known. As can be seen from the figure, vLMS offers worse performance than the AR2-KF architecture, but is still acceptable. In addition, the vLMS algorithm is able to be readily realized in hardware.

IV. FPGA IMPLEMENTATION

While implementation of the transmitter is non trivial, the receiver side represents significantly more complexity. As such, here we will only address the components and associated complexity of the receiver targeted to our host FPGA. The

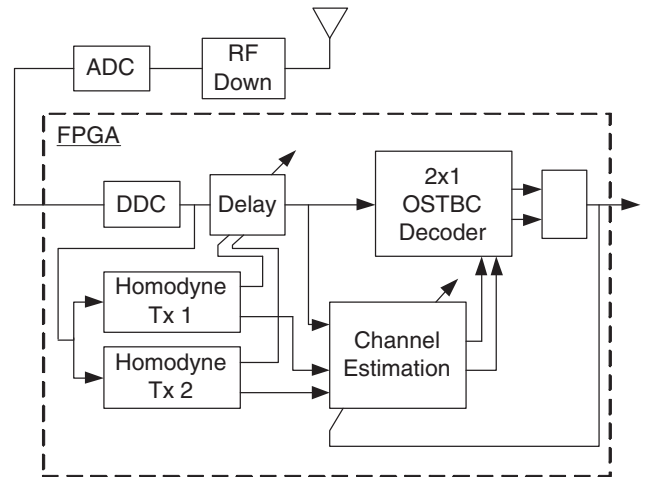

Fig. 4. Receiver architecture.

overall architecture is shown in Figure 4. From the figure we see there are several components, most of which have been discussed. The one exception is the digital down converter (DDC) and OSTBC decoder [2]. The DDC itself is responsible for front-end filtering and translation from our intermediate frequency (IF) of 12 MHz to baseband. The baseband output is presented with an oversampling rate of sixteen and a symbol rate of 500 kbps.

The complete transceiver has been targeted to a Xilinx Virtex-4SX FPGA. The resource use for each portion of only the receiver section of the complete transceiver is shown in Table I. The clocking frequency of the device is 64 MHz. As can be seen from the table, the channel estimation and decoding blocks represent the most cost in terms of computational complexity. We also note the hardware complexity for these blocks scales approximately linearly as a function of the number of nodes forming the VAA.

V. CONCLUSION AND FUTURE WORK

In this paper we have presented a technique that can be used to increase the link reliability of wireless nodes, particularly when transmitting over long range with NLOS conditions. Our proposed architecture is to employ space-time coding, implemented across a set of distributed nodes. While able to reduce the necessary link margin, through channel diversity, there are several associated technical challenges for such an implementation. In particular, as the nodes no longer share a common crystal we lose synchronization over carrier frequency. Additionally, as the medium access control (MAC) layer is not synchronized, there are special timing considerations that must be made. Our solution for this problem is to use a high oversampling rate and employ training sequences to make accurate time offset estimates. Through the ability to have accurate time resolution, relatively good synchronization can be achieved. As such, a minimum of orthogonalization is lost between code pairs. We note that use of an OSTBC

TABLE I
HARDWARE RESOURCES ON VIRTEX-4SX35 PROCESSOR FOR 2X1 STC RECEIVER.

	Flip Flop (FF)	Lookup Table (LUT)	SLICE	DSP48/BRAM	Performance (ns)
Available Resources	30720	30720	15360	192	N/A
DDC	4138	2972	2347	0	5.72
Two Channel Homodyne-Correlator	5315	5017	3317	11	12.91
Two Channel Time-Frequency Estimation	7912	7218	6922	4	25.62
vLMS Channel Tracker and Two Channel STC Decoder	773	2278	1117	36	45.8
Total	18480	18119	14092	51	96.95
Percentage Used	60.16%	58.98%	91.74%	26.56%	

requires the nodes to share a common set of data. This is the case for fused sensor data, but it is also assumed that the cost for inter-node communication is essentially free compared to communication to the collector, due to necessary higher transmit power.

Looking towards practical hardware implementation, the algorithms presented here are specifically meant to stress reduced computational complexity over absolute performance. This includes not only the problem of timing and frequency offset estimation, but also channel estimation. As such, we propose the use of the LMS filter for channel tracking as opposed to the higher performance Kalman filter. We note the LMS filter offers a dramatic reduction in hardware complexity and has increased stability. Illustrating the feasibility of our design, we presented the implementation complexity on a readily available FPGA, namely a Xilinx Virtex-4SX processor.

Future work will focus on field testing and higher-level synchronization. In terms of synchronization, our goal is maintain as much of the MAC layer in the FPGA as possible in order to maintain constant processing time. We note that any interaction between the base processor and FPGA will result in unknown time offsets. While possibly small, the result will be reductions in synchronization accuracy. Field testing will focus on determining resulting range extension under typical operating conditions.

ACKNOWLEDGMENT

This work was supported by the Air Force Office of Scientific Research under Contract No. FA9550-05-C-0179. The authors would like to thank Dr. Jon Sjogren for his support and input.

REFERENCES

- [1] W. Jakes, *Microwave Mobile Communication*. John Wiley and Sons, 1974.
- [2] S. M. Alamouti, "A simple transmit diversity technique for wireless communications," *IEEE Trans. on Selected Areas in Communications*, vol. 16, pp. 1451–1458, Oct. 1998.
- [3] V. Tarokh, H. Jafarkhani, and A. R. Calderbank, "Space-time block codes from orthogonal designs," *IEEE Trans. on Information Theory*, vol. 45, pp. 1456–1467, July 1999.
- [4] R. A. Iltis, R. E. Cagley, B. T. Weals, S. Mirzaei, and R. Kastner, "Carrier offset and channel estimation for cooperative MIMO sensor networks," in *Proc. IEEE Global Telecommunications Conference*, Nov. 2006.
- [5] G. Foschini and M. Gans, "On limits of wireless communication in a fading environment when using multiple antennas," *Wireless Personal Communications*, vol. 6, pp. 311–335, 1998.
- [6] H. Ochiai, P. Mitran, H. V. Poor, and V. Tarokh, "Collaborative beamforming for distributed wireless ad hoc sensor networks," *IEEE Trans. on Signal Processing*, vol. 53, pp. 4110–4124, Nov. 2005.
- [7] M. Dohler, J. Dominguez, and H. Aghvami, "Link capacity analysis for virtual antenna arrays," in *Proc. IEEE 56th Vehicular Technology Conference*, vol. 1, Sept. 2002, pp. 440–443.
- [8] M. Dohler, A. Gkelias, and A. H. Aghvami, "Capacity of distributed PHY-layer sensor networks," *IEEE Trans. on Vehicular Technology*, vol. 55, pp. 622–639, March 2006.
- [9] P. Dent, G. Bottomley, and T. Croft, "Jakes fading model revisited," *IEEE Electronics Letters*, vol. 29, pp. 1162–1163, June 1993.
- [10] T. S. Rappaport, *Wireless Communications*. Prentice Hall, 1996.
- [11] Ph.-Y. Wu and A. Duel-Hallen, "Multiuser detectors with disjoint Kalman channel estimators for synchronous CDMA mobile radio channels," *IEEE Trans. on Communications*, vol. 48, pp. 752–756, May 2000.
- [12] B. Widrow and S. D. Stearns, *Adaptive Signal Processing*. Englewood Cliffs, NJ: Prentice-Hall, 1985.
- [13] T. Aboulnasr and K. Mayyas, "A robust variable step-size LMS-type algorithm: analysis and simulations," *IEEE Trans. on Signal Processing*, vol. 45, pp. 631–639, March 1997.