

CS423: Lectures 2-4, Physical Layer

George Varghese

April 16, 2008

What does the Physical Layer Do?

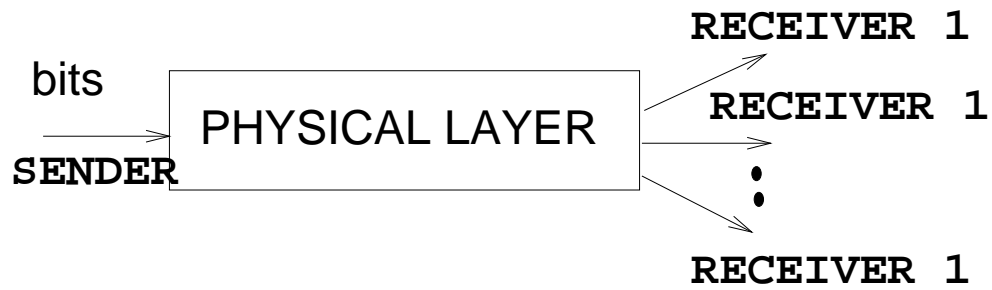

- A possibly faulty, single-hop, bit pipe that connects a sender to possibly multiple receivers

Morse Code Analogy

Example bit pipe: sending Morse Code to receivers using a flashlight. Issues:

- **Fundamental Limits:** Brain-eye system processing limits leads to Inter Symbol Interference
- **Media Issues:** Flashlight, semaphore
- **Coding:** Morse code, getting in synch, knowing receiver rate.

PHYSICAL LAYER: SUBLAYERS

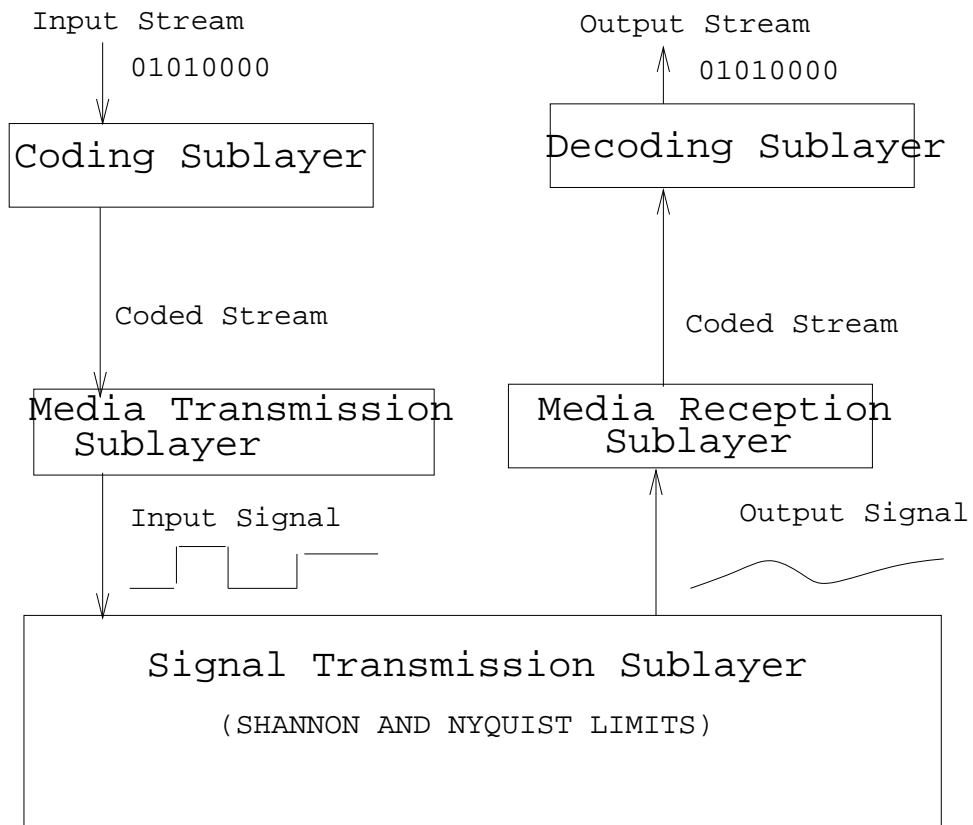

Why understand the Physical Layer in Sublayers?

- The bottom sublayer is really describing the essential properties of the media (frequency response, bit error rate). These influence data transmission rates (Nyquist, Shannon limits). This lecture.
- The middle sublayer describes properties of particular media — e.g.. satellites, coaxial cable, fibre.
- The top sublayer is about things like clock recovery, synchronization etc.

Sublayers can be studied independently. Separate concerns. Each sublayer exacts its price!

1.0 Bottom Sublayer: Signal Transmission and Limits

Sending bits to a receiver

- **Goal:** to send a sequence of 0's and 1's from a sender to a receiver by sending energy (e.g., light, electricity) over a channel (e.g., fiber, cable). One coding: 0 = no energy, 1 = energy.
- **Problem:** Real channels distort input energy signals. Leads to two questions.
 - **Q1:** How can we predict what a given channel will do to an input signal given some properties of the channel. **Answer:** Fourier Analysis.
 - **Q2:** How does distortion affect maximum bit rate? **Answer:** Nyquist (sluggishness) and Shannon (noise) limits.

Signals, and channels

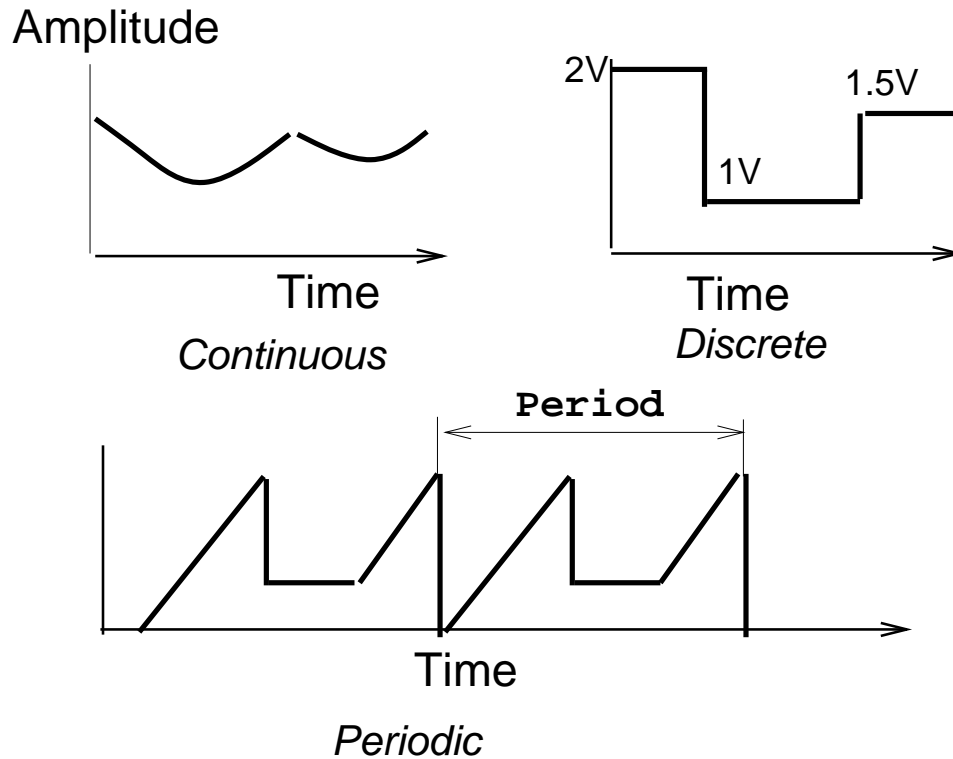

- **Signal:** energy (e.g., voltage, light) that varies with time. Continuous and Discrete. Periodic. Period and frequency.
- **Channel:** physical medium that conveys energy from a sender to a receiver (e.g., a fiber link) with possible distortion.

Sine Waves

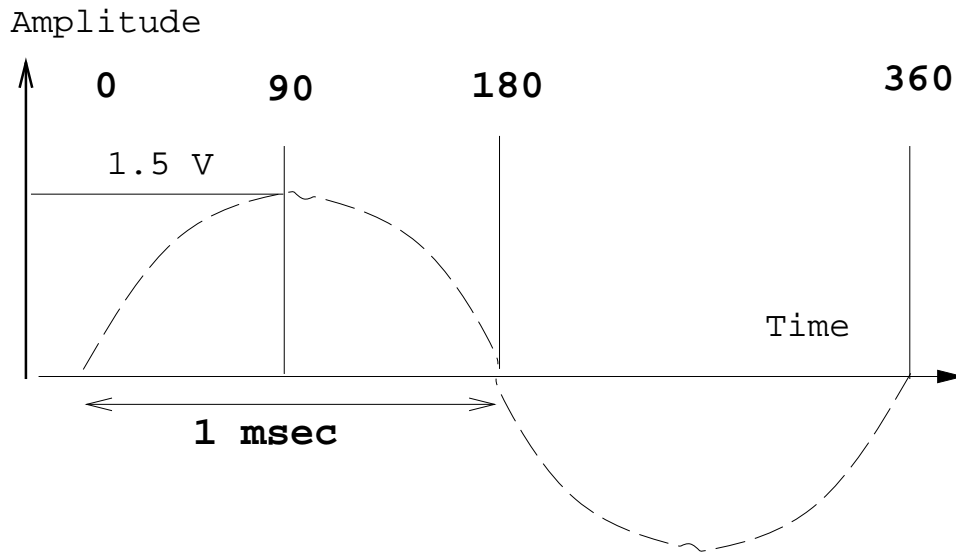

- Sine waves are special because all signals can be rewritten in terms of sine waves.
- Mathematically: $A \sin(2\pi ft + \theta)$, A is max value, f is frequency, θ is initial phase shift
- Example: Frequency 1 Hz, $\theta = 0$. Values at $t = 0$ and $t = 1/4$. Use calculator but express angle in radians!

Fourier Analysis: the big picture

- If we forget about noise, most channels are “nice” to sine waves. A sine wave of frequency f is always scaled by a fixed factor $s(f)$ and phase shifted by a fixed amount $p(f)$ regardless of amplitude.
- Thus we can completely describe a channel by plotting the values of $s(f)$ (frequency response) and $p(f)$ (phase response) for all values of frequency f .
- To find what happens to arbitrary signal S , we **i)** Use Fourier Analysis to rewrite S as a sum of sine waves of diff frequencies **ii)** Use frequency and phase response to see effect of each sine wave **iii)** Add scaled sine waves to find output signal.

Frequency and Phase Response Examples

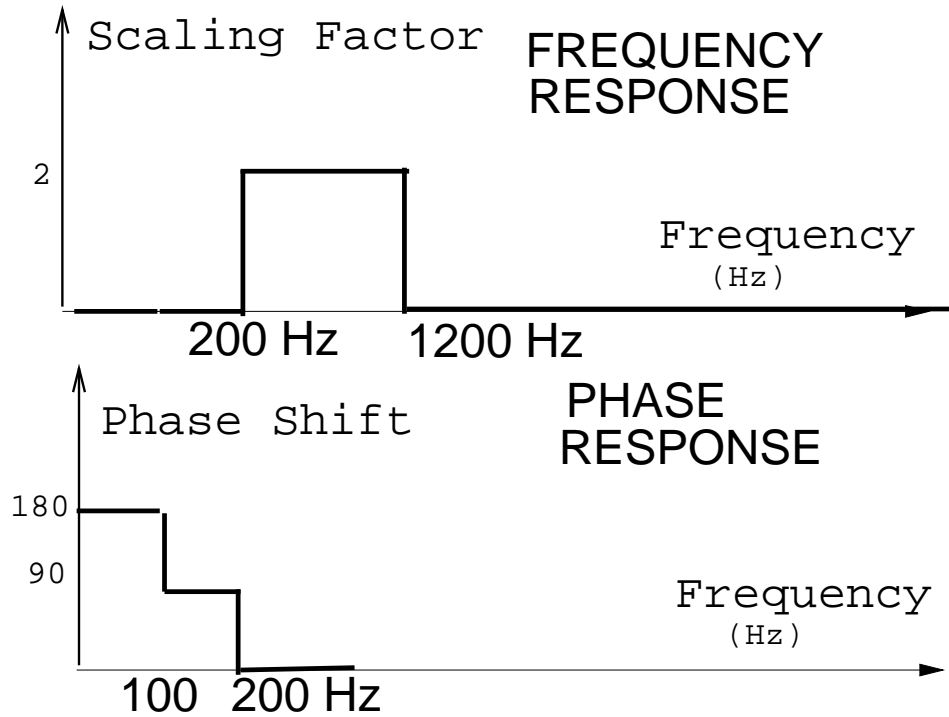

- Bandwidth: range of frequencies for which channel passes signal through. Not very precise.

Sluggishness and Noise

- Most channels are sluggish (they take time to respond) because they turn a deaf ear to higher frequencies in the input signal. Thus lower bandwidth channels are more sluggish.
- What about noise? Different models for different channels. Simplest and common model: white noise (uniformly distributed at all frequencies and normally distributed within a frequency)

Sampling Bits

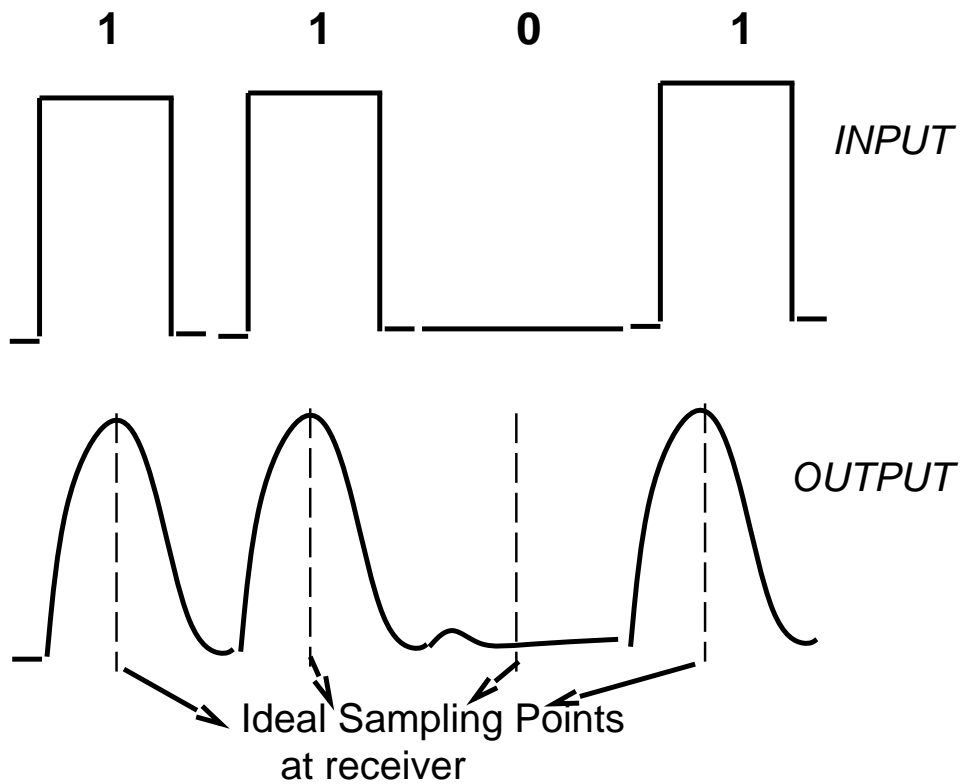

- Receivers recover the bits in the input signal by *sampling* output signal close to middle of bit period.
- Two limits to bit rate: channel bandwidth (Nyquist) and noise (Shannon).

Bandwidth and Intersymbol Interference

- We know that a channel that cannot pass frequencies beyond f cannot respond fast enough if signals are sent at a rate faster than f .
- If we do so, then when the first signal is still “settling”, the energy of the second signal will start mixing in. If first signal is a 0 and second is a 1, receiver may decode incorrectly.
- Technically, we say that signalling at a rate higher than the channel bandwidth causes Inter Symbol Interference or ISI.

NYQUIST LIMIT

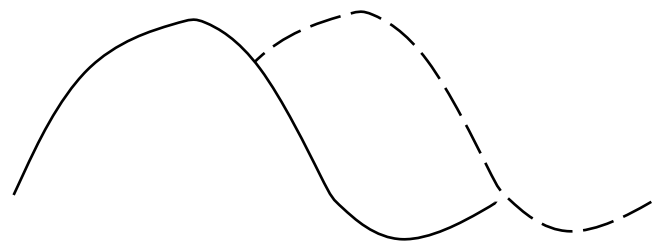
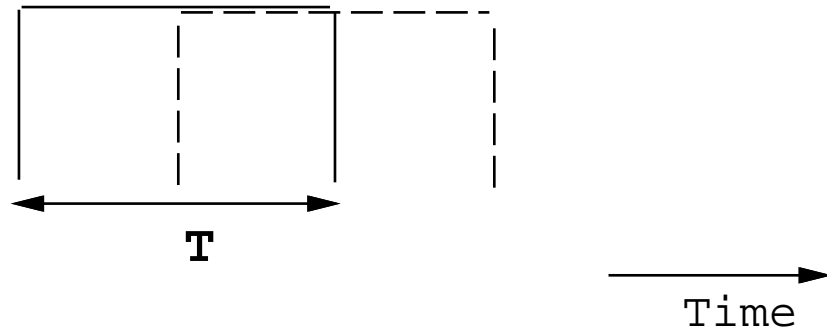

Signal frequency = $1/T = f$

Maximum Signal Rate = $2/T = 2f$

Works only if we have removed
frequency components above f

Baud Rate and Bit Rate

- To prevent ISI, we cannot signal at faster than $2f$ times per second. Baud rate is max signalling rate.
- But each symbol in a signal can carry multiple bits. For example: 0, 2, 4 and 5V. 4 possible values and 2 bits per symbol.
- With L signal levels, bit rate is $\log L$ times baud rate.
- So why can't we transmit at terabits over a phone line? Noise.

THE SHANNON BOUND

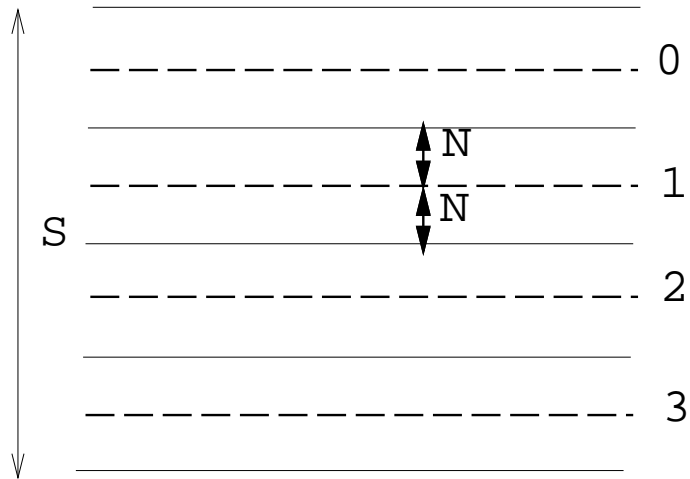

S = Maximum Signal Amplitude

N = Maximum Noise Amplitude

$\log(S/2N)$ bits per signal

$2 B$ signals/sec (Nyquist)

Naive Bound = $2 B \log(S/2N)$

Shannon Bound = $B \log(1 + S/2N)$

2.0 Top Sublayer: Clock Recovery

Who needs a clock anyway?

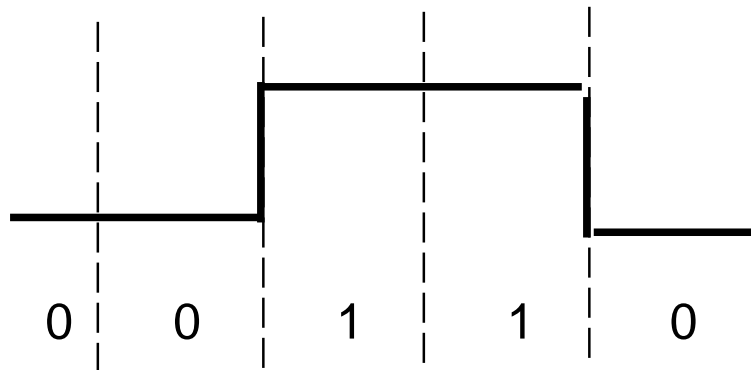
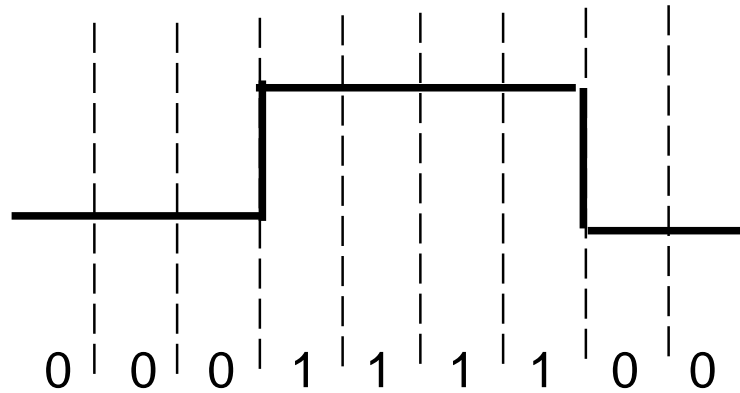

- How to initially synchronize receiver clock with sender clock? **Initial Training Bits**
- Problem: All real physical clocks drift over time. Crucial at high speeds. Small drift leads to sampling error. How to keep in synch?

Transitions

Transitions and Coding

- Parse: nohewontgosoan. Need spaces and punctuations to parse speech.
- Stream of bits without transitions (change in signal value) equally hard to parse.
- Real data may contain all 0's. How can you ensure transitions. Coding. Adds cost.
- Code to ensure that every n bits you get at least m transitions. Different coding schemes parameterized by n and m .

Asynchronous Coding

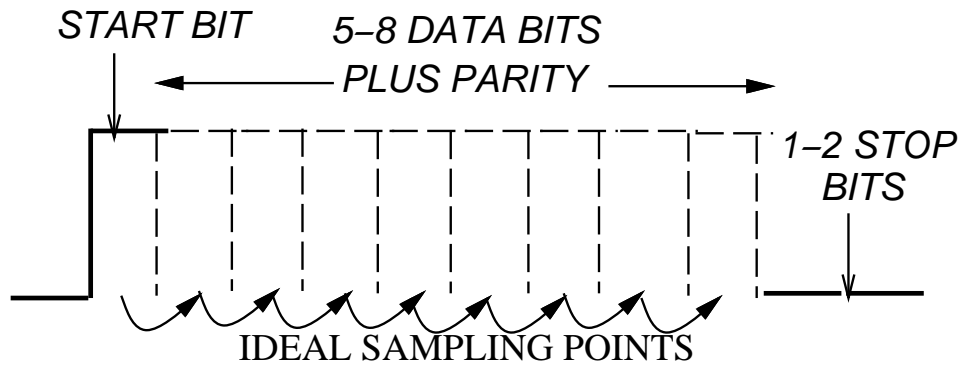

- Codes a character (5-7) bits at a time. ASCII. Adds parity bit.
- Character is framed using a start bit and one or two stop bits. 1 is encoded as low voltage, 0 as high.

Why Synchronous Transmission

- For Clock Recovery, receiver must know when to start its receive clock (phase). Then can sample the line at periodic intervals at the same rate as sender clock with some help from transitions in data.
- In asynchronous, receiver gets locked in phase when the voltage goes from low to high (start bit). Need to have fairly large idle time between characters for receiver to get locked in phase for each character; slows transmission and limits it to low rates.
- Two overheads to start bits: extra bit but also extra time needed for reliable detection. (Starting up receiver clock is expensive)
- In synchronous, we put a large number of start bits at the start of a large number of data bits. This allows the startup overhead to be amortized.

Getting locked in phase

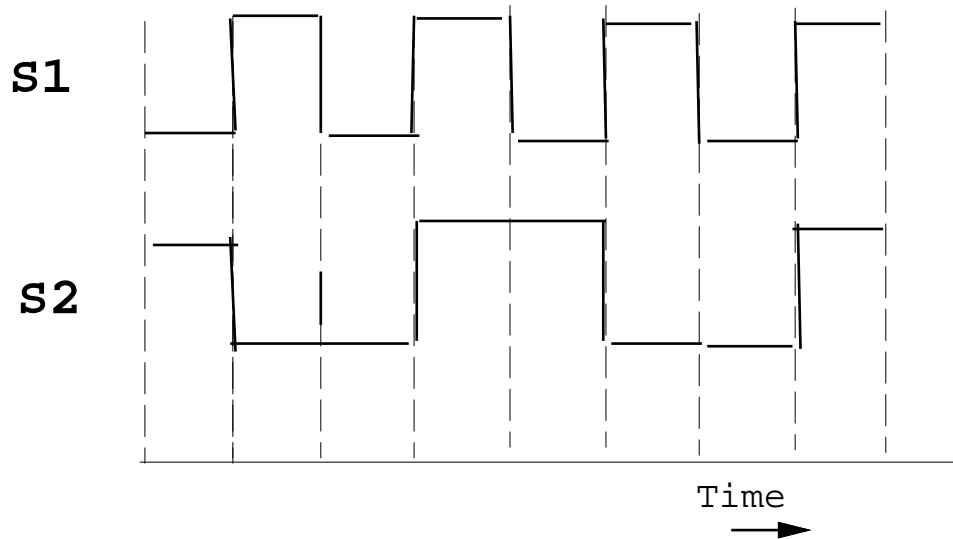

- In asynchronous you get in phase by a single 0 to 1 transition. Not very reliable in the presence of noise.
- In Manchester, you get in phase by sending a preamble or group of start bits of the form 010101 in which the only transitions are at mid bit; easy to recognize and get locked in phase.

Phase Locked Loops

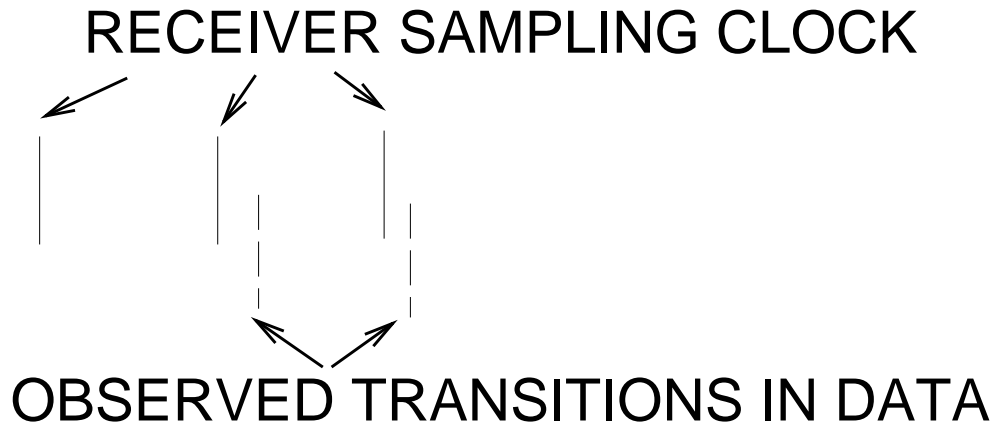

- Once you lock in at the start of a data unit, you can rely on accuracy of receiver clock frequency (as in asynchronous). Can't do that if data unit is large (as in synchronous).
- Could try resetting receiver clock on every observed transition. Susceptible to noise. Better to use more gradual adjustment.
- Phase Locked Loops measure phase difference and speed up or slow down receiver clock to reduce phase difference. Commonly used.

Eye Patterns

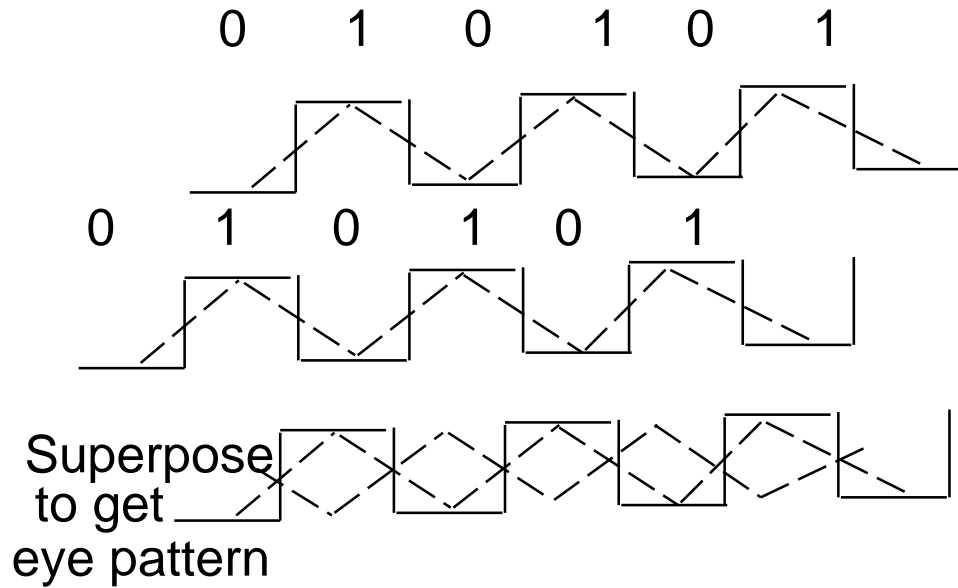

- In a perfect system, we will have a well-defined eye. Should sample at center of eye. Nice visual test of line quality.

"SYNCHRONOUS" TRANSMISSION

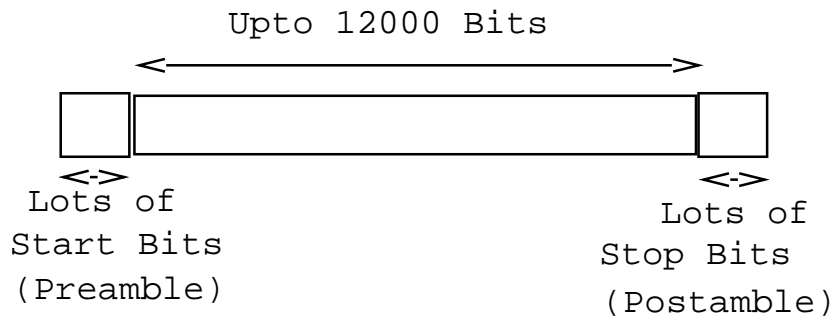

same as asynchronous except larger frame sizes . It requires better clock tolerance and more sophisticated coding.

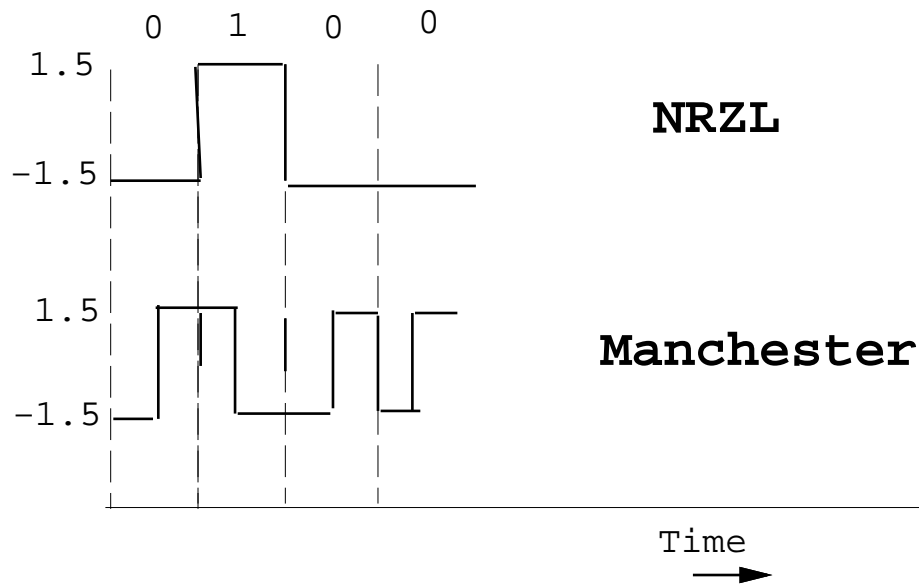

Evaluation Criteria

Coding Efficiency (Real Bits/Coded Bits)

Signal to Noise Ratio

DC Balance

Implementation Complexity

Broadband Coding

- (So far) Baseband Coding using energy levels such as voltage or light. In *broadband coding* information is *modulated* on a carrier wave of a certain frequency. Used by modems.
- Modulation refers to changing the properties of the carrier to convey the required information.
- Frequency Shift Keying (FSK): high frequency encodes a 1 and low a 0, Amplitude Shift Keying (ASK): high amplitude encodes a 1. QAM (multiple amplitudes and phases)

MULTIPLEXING (SHARING)

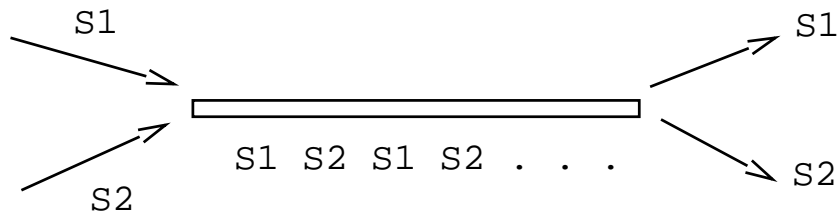

TIME DIVISION MULTIPLEXING (TDM)

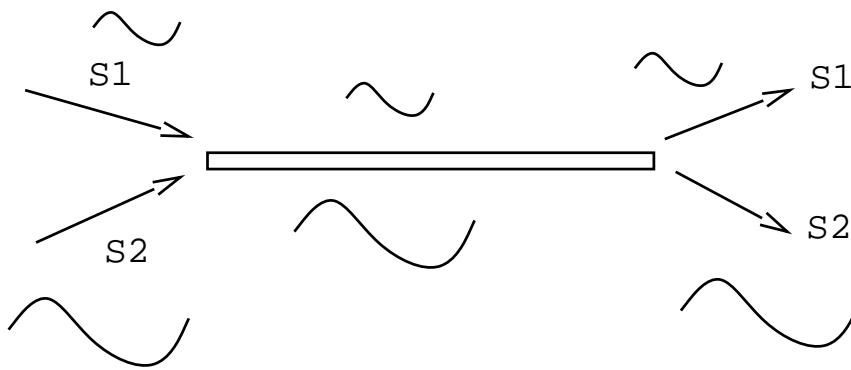

FREQUENCY DIVISION MULTIPLEXING (FDM)

3.0 Middle Sublayer: Media Specific Challenges and Opportunities

Media Affects Protocols

- **Low Bandwidth led to tight encoding:**
Early Phone lines, not needed on LANs
- **Broadcast LANs led to use of Multicast:**
Initialization and free copies, to IP multicast.
- **Building wiring led to Switching:** Wiring closets to hubs to ATM switches.
- **Fiber led to rings:** Point-to-point fibers lead to rings.
- **Fiber led to Digital:** Long haul telephone network becomes digital.
- **Wireless leads to low bandwidths again:**
Laptops. Need Ipv6 compression on wireless links!

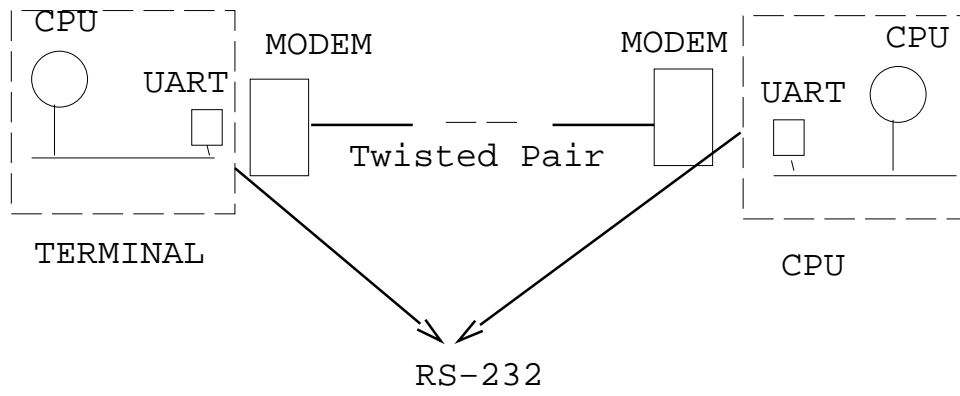

Low bandwidth
Cheap, Easy to Install

Using Twisted Pair for Higher Rates Today

- Standard twisted pair is limited by loading cables by telephone company to 4 Mhz. Shannon limit is around 56 Kbps (not counting compression). Two alternatives
- Better quality twisted pair cables for local area networks e.g., Cat 3 (10 Mbps, Manchester), Cat 5 (100 Mbps, 100 Mhz bandwidth uses 4-5 coding)
- Telephone company removes loading cables, reduces your length, and gives you ADSL. Asymmetrical.

BASEBAND CABLE (e.g. ETHERNET)

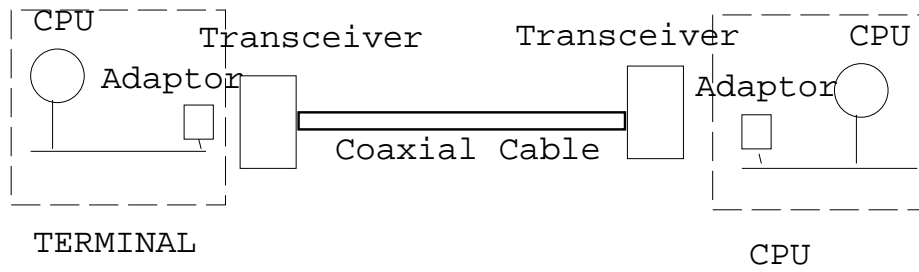

High bandwidth (10-100 MHz)

Hard to tap, expensive to Install

Small Distance (1 - 3 km without repeaters)

Using Coaxial Cable Today

- Coaxial cable has high bandwidth. Used for original 10 Mbps Ethernet but very clunky. Twisted pair (e.g. Cat 5) used today.
- Cable still used in cable networks for cable TV and for data via cable modems. Divide bandwidth into 6 Mhz channels for each TV channel and one 6 Mhz channel for downstream data. Theoretically can reach 30 Mbps but beware other users and bandwidth limits. Upstream much less.

FIBRE OPTICS

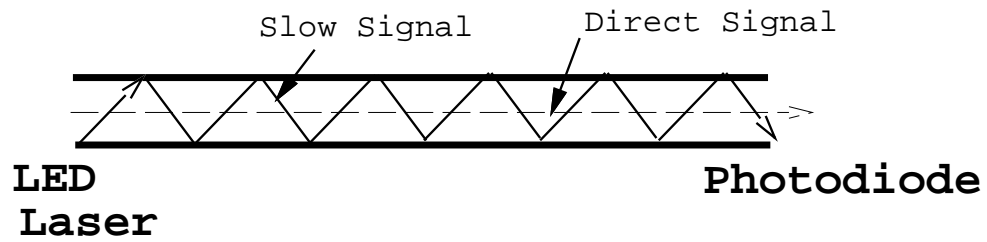

Huge Bandwidth (10 Million Mhz!)

Almost Impossible to Tap

Point-to-point

Secure

Excellent Electrical Isolation

Thin and Easy to Install

Optics still expensive

Unidirectional

MICROWAVE

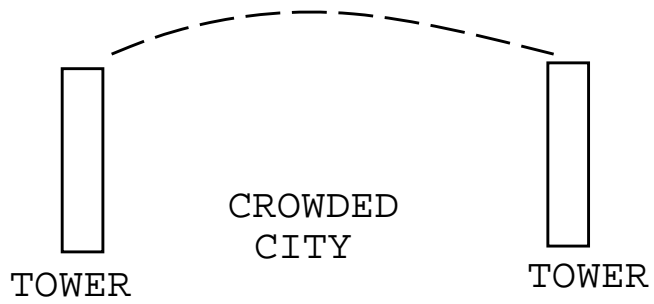

Avoids Right of Way

May be cheaper than installing cable

Reasonable Bandwidth

Has problems with Rain

Upto 100 km distance

SATELLITE

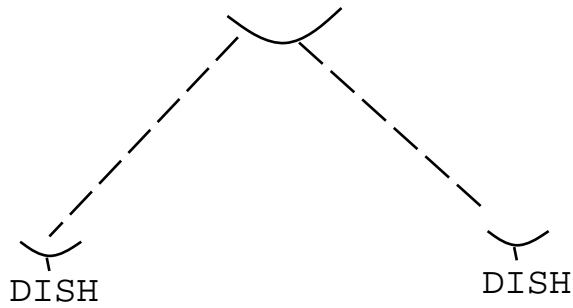

Avoids Right of Way

Good Bandwidth (500 Mhz)

World Wide

Large Latency

Antenna Cost

READING ASSIGNMENT: Section 2.2

Wireless Data Transmission Options

- 802.11: Wireless LANs using a wireless access point (AP) at hot spot using unlicensed frequency band 2.4 to 4.485 Ghz (radio frequency) 100 metres. 11 Mbps with 802.11b. Needs hotspot but becoming common and very cheap!
- Bluetooth: ad hoc personal area networks with no AP. Master-slave. 4 Mbps
- WiMax: broader geographical range smaller bandwidth of a few Mbps
- 3 G (Cellular telephone networks carrying data) at a few Mbps such as EDO. Unlimited geographical range and true mobility

802.11b in some more detail

- AP configured with a SSID that you can see when doing View Available Networks and a channel number from 1 to 11. Non-overlapping channels (1, 6, 11) can be used to triple bandwidth
- Each AP periodically sends a beacon containing SSID.
- Each AP scans all 11 channels looking for beacons to get a list of networks. Some choice of AP and then mobile sets up an association
- Access protocol to send data tricky because of hidden terminal problem. Mobile A can send to base station and so can Mobile B, but A and B cannot hear each other but can interfere at base station. Needs careful protocol design (later)

	Bandwidth	Span	Disadv	Adv
Twisted Pair	< 1Mbps	1-2Km	low speed	cheap, easy to install
Digital Coax	10-100Mbps	1-2km	hard to tap, install	broadcast
Analog Coax	100-500Mbps	100km	exp. analog amplifiers	cable companies use it now!
Satellite	100-500Mbps	worldwide	prop delay antennas	no right-of-way cost does not depend on distance
Microwave	10-100Mbps	100km	fog outages	no right-of-way
Fiber	terabits	100km	no broadcast no mobility	security isolation bandwidth
Infrared RF	< 4 Mbps 115 kbps	3 m 1 km	obstacles for infrared	wireless

ETHERNET TRANSMISSION

