

## Midterm 1 Problems

1. Show the arrangement of transistors needed to construct a gate whose output F is the inverted value of  $F(A, B, C) = (A + B + C)(\bar{A} + B)(\bar{A} + B + C)$ .

Try to minimize the number of transistors involved.

Place the arrangement of transistors within the dashed boxes below, making sure to make appropriate connections to the ground, the high voltage, the inputs A, B, C, and the output F.

(20 points)

### Solution and Grading:

$$(A + B + C)(\bar{A} + B)(\bar{A} + B + C) = (A + B + C)(\bar{A} + B) = (B + (A + C))(B + \bar{A}) = B + \bar{A}(A + C) = B + \bar{A}C$$

$$F(A, B, C) = (B + \bar{A}C)$$

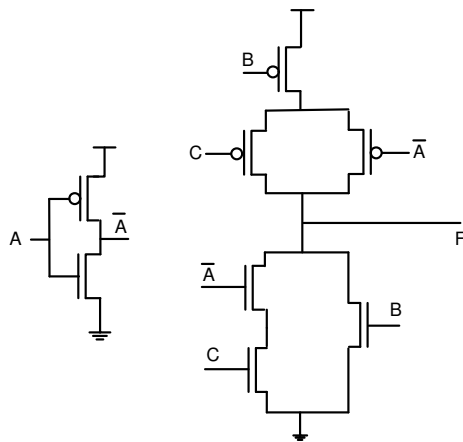

2. Consider the following two Boolean functions (10 marks)

$$F(X, Y, Z) = \overline{\overline{(X)}(\overline{Z}) + Z + Z(\overline{Y})} + (X + 0)(\overline{Z} + Y)(\overline{Z} + \overline{Y})(Y + 1)$$

$$G(X, Y, Z) = X(\overline{Z})$$

Using the theorems of Boolean algebra, prove that  $F(X, Y, Z) = G(X, Y, Z)$   
(10 points)

**Solution:**

$$F = (X'Z' + Z + ZY')' + ((X+0)(Z'+Y)(Z'+Y')(Y+1))$$

$$= (X'Z' + Z)' + ((X)(Z'+Y)(Z'+Y'))$$

$$= (X'+Z)' + ((X)(Z'+Y)(Z'+Y'))$$

$$= XZ' + XZ'$$

$$= XZ'$$

3. Implement this function using only NOR gates. How many NOR gates will you need?  
(10 points)

**Solution:**

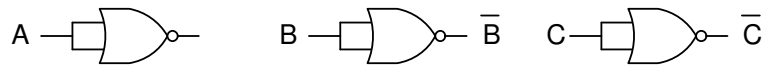
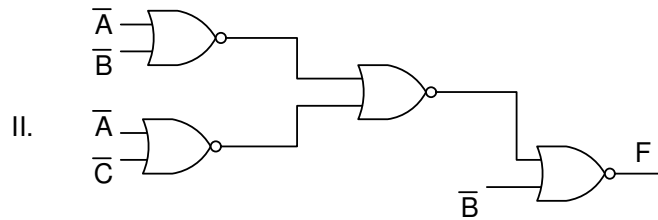
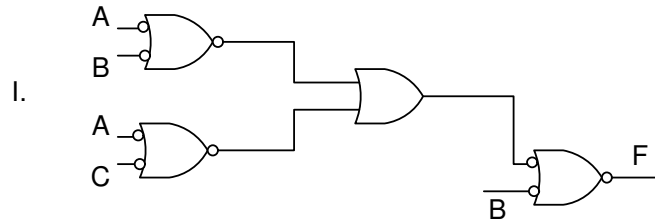
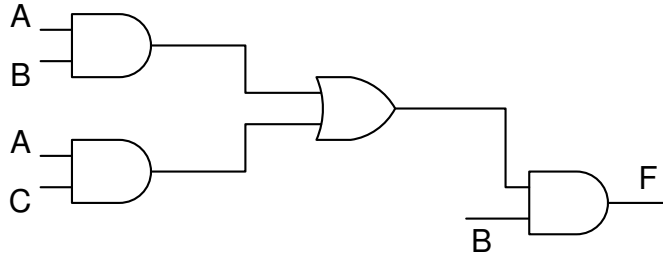

4. Consider the following Boolean function:

$$F(A, B, C, D) = m(0, 4, 5, 10, 12, 13, 14) + d(3, 8, 15)$$

What is the corresponding KMap for F?

Identify all prime implicants of F. (10 marks)

What are the essential prime implicants. (5 marks)

**Solution:**

- What is the corresponding KMap for F? (5 marks)

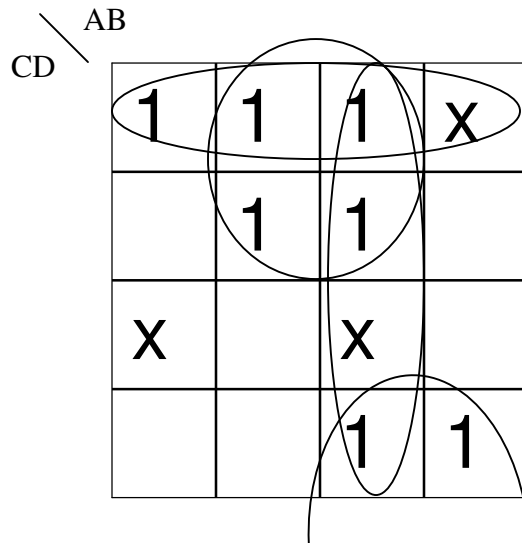

- Identify all prime implicants of F. (10 marks)

AB  
 $C' D'$   
 $C' B$   
 $A D'$

- What are the essential prime implicants. (5 marks)

$C' D'$   
 $C' B$   
 $A D'$

- Give one minimized Sum-of-Products form for F (5 marks)

$C' D' + C' B + A D'$

5. Implement each of the given functions F1 and F2 in multi-level logic using two-input AND and OR gates.

Minimize the number of logic gates by implementing the two functions in a single circuit.  
(Hint: share the gates between the two functions)

$$F1(A, B, C, D) = \sum m(5, 7, 10, 13, 14, 15)$$

$$F2(A, B, C, D) = \sum m(0, 2, 4, 5, 6, 7, 8, 12, 13, 15)$$

**Solution and Grading:**

F1

|   |   |   |   |   |   |
|---|---|---|---|---|---|
|   | A |   |   |   |   |
|   | 0 | 0 | 0 | 0 |   |
|   | 0 | 1 | 1 | 0 | D |
| C | 0 | 1 | 1 | 0 |   |
|   | 0 | 0 | 1 | 1 |   |
|   | B |   |   |   |   |

F2

|   |   |   |   |   |   |
|---|---|---|---|---|---|
|   | A |   |   |   |   |
|   | 1 | 1 | 1 | 1 |   |
|   | 0 | 1 | 1 | 0 | D |
| C | 0 | 1 | 1 | 0 |   |
|   | 1 | 1 | 0 | 0 |   |
|   | B |   |   |   |   |

$$F1(A,B,C,D) = BD + D'(AC)$$

$$F2(A,B,C,D) = BD + D'(A'+C') = BD + D'(AC)'$$

Implementing only F1

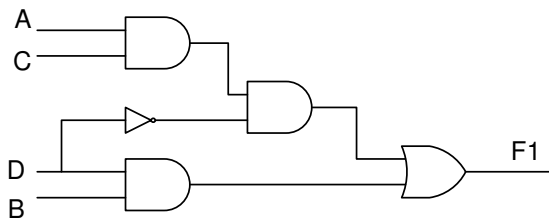

Two alternative implementation for only F2:

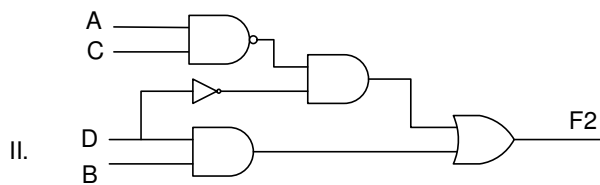
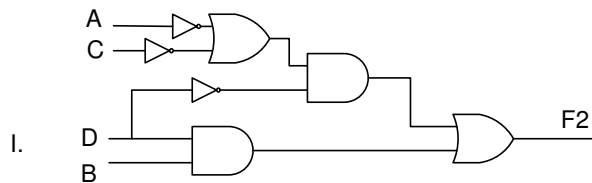

Implementing both functions together.

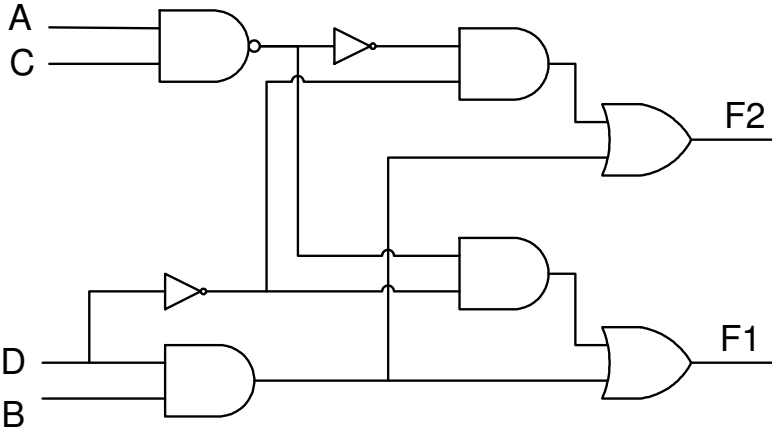

6. Draw the KMap for the function  $F(A,B,C,D) = \prod M(2, 3, 6, 8, 9, 12, 13, 14)$   
 Determine the minimized function in product of sums form.  
 Are there any static-0 hazards in the minimized function? If yes, find them and eliminate them.

(15 points)

**Solution:**

Correct Karnaugh Map: 5 pts (-2 for each incorrect value)

|   |   |   |   |   |   |
|---|---|---|---|---|---|
|   |   | A |   |   |   |
|   |   | 1 | 1 | 0 | 0 |
| C | 1 | 1 | 0 | 0 | D |
|   | 1 | 1 | 0 | 0 |   |
|   | 0 | 1 | 1 | 1 |   |
|   | 0 | 0 | 0 | 1 |   |
|   |   | B |   |   |   |

The minimized function in SoP form is:

$$F(A,B,C,D) = (A' + C)(A + B + C')(B' + C' + D)$$

Hazard free version:

$$F(A,B,C,D) = (A' + C)(A + B + C')(B' + C' + D)(A + C' + D)(A' + B' + D)$$

7. (Bonus) Implement the function  $F$  using the 8 input multiplexor as shown below.  
 $F(A,B,C,D) = \sum m(2, 3, 7, 9, 10, 13, 14) + d(12, 15)$   
**(10 points)**

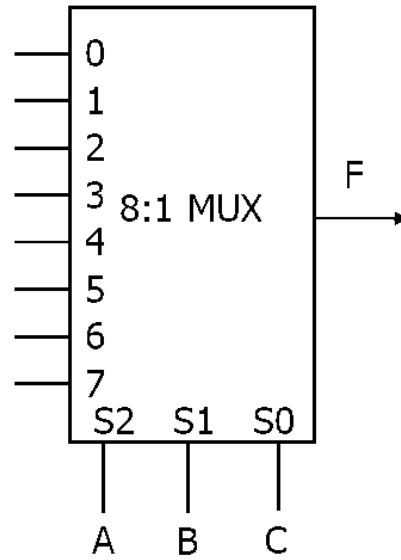

**Solution:**

| A | B | C | Function |
|---|---|---|----------|
| 0 | 0 | 0 | 0        |
| 0 | 0 | 1 | 1        |
| 0 | 1 | 0 | 0        |
| 0 | 1 | 1 | D        |
| 1 | 0 | 0 | D        |
| 1 | 0 | 1 | D'       |
| 1 | 1 | 0 | 1 or D   |
| 1 | 1 | 1 | 1 or D'  |