

Fetch Unit

CSE141L Lab 1b

Fetch Unit?

- Fetch instructions from I-mem
- Supply instructions to the Exec Unit
- Why use a FIFO?

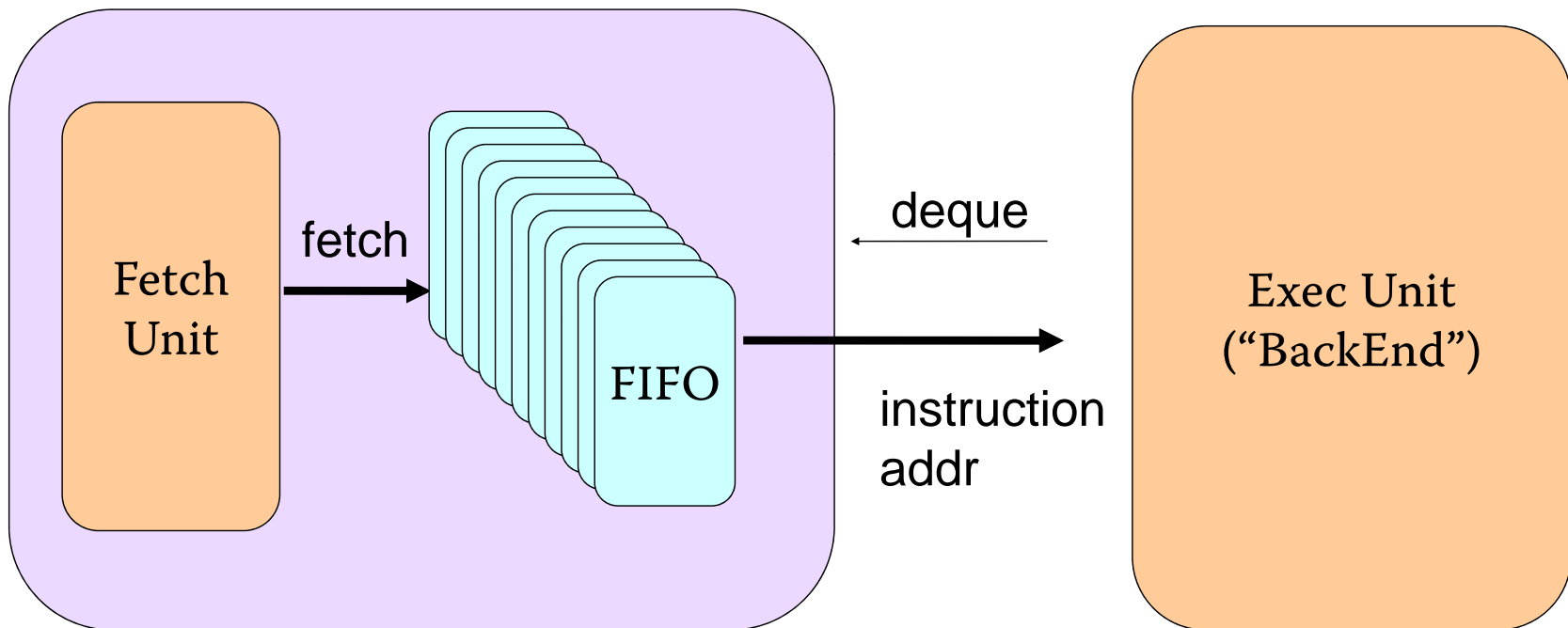

Fetch Unit Roles

- Supply instructions to the exec unit
- Service I-Mem operations
 - load an instruction
 - store an instruction
- Branch Prediction
 - if (cond) do A, else do B
 - fetch A or B?
 - Instead of waiting the result of condition evaluation, predict where to go
 - For a misprediction, a recovery mechanism required

Simple Static Branch Prediction



- P(1bit) - prediction bit
 - 0: not a branch, or a branch predicted untaken
 - 1: a branch, and predicted taken
- Branch target address
 - PC(10bits) + Offset(5bits)

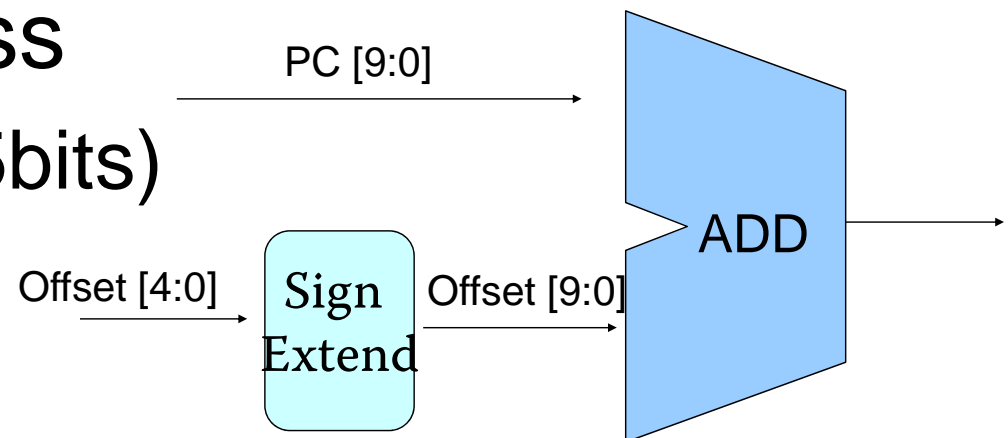

Fetch Unit Interface

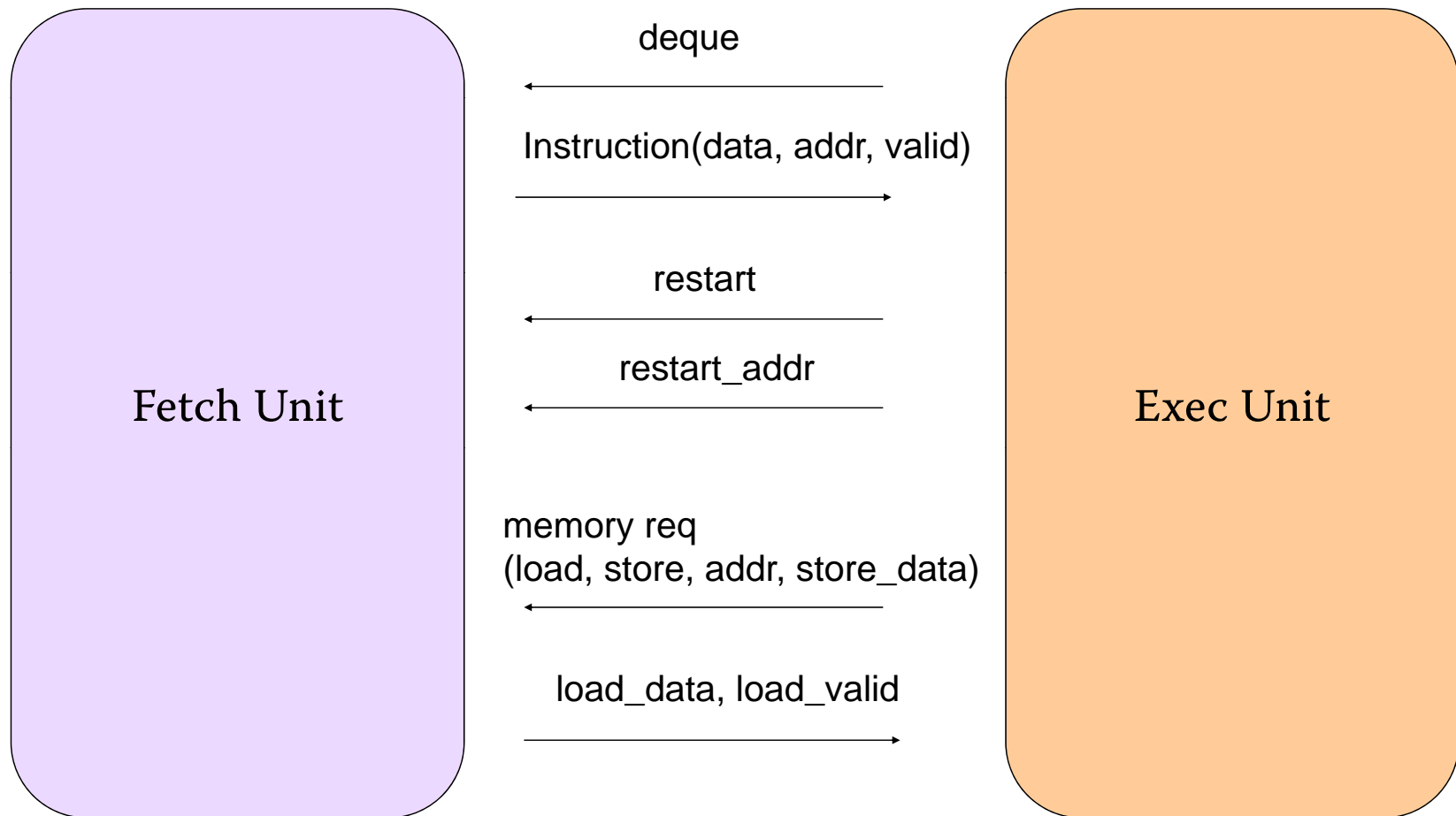

```
module fetch #(parameter I_WIDTH = 17, A_WIDTH = 10, O_WIDTH= 5)
(
    input clk, reset,

    // normal operation, signals from the backend end
    input deque,
    input restart,
    input [A_WIDTH-1:0] restart_addr,

    // normal operation, signals from the front end to backend
    output [I_WIDTH-1:0] instruction_data,
    output [A_WIDTH-1:0] instruction_addr,
    output instruction_valid,

    input [A_WIDTH-1:0] load_store_addr,
    input [I_WIDTH-1:0] store_data,
    output [I_WIDTH-1:0] load_data,
    output load_valid,
    input load_store_1_0;
    input do_load_store;
)
```

Fetch Unit Operations

- deque
 - simple
- fetch
- restart
- memory
 - load
 - store

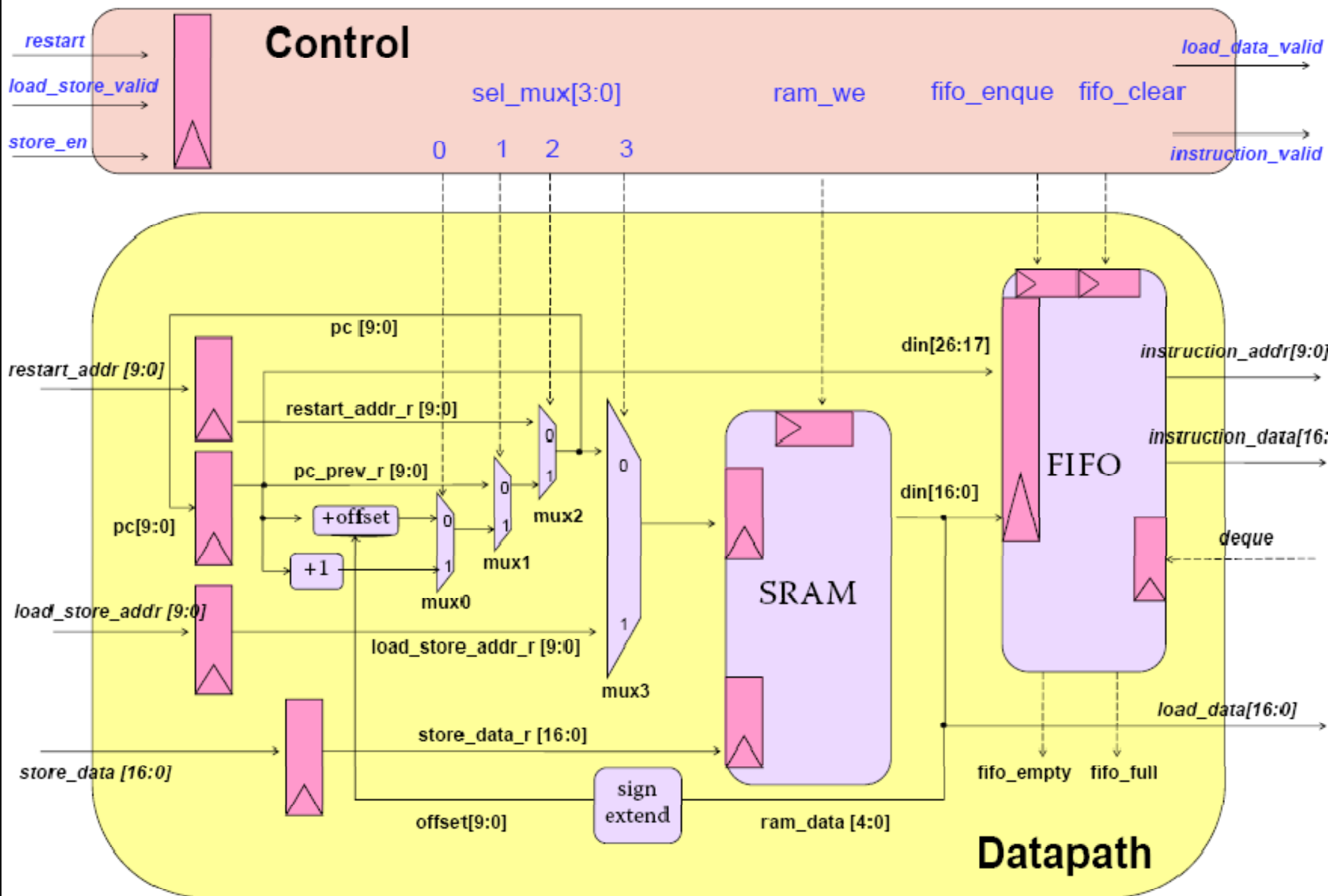

Operation - Fetch

- If reset
 - Fetch the instruction at 0x0
- Else If (branch | branch_predicted)
 - Fetch the instruction at the branch target address
- Else
 - Fetch the instruction at {PC + 1}

Operation - Restart

- Why Restart?
- Operations
 - discard all the instructions in FIFO
 - Fetch the instruction at restart_addr
- Priority?
 - Reset > Restart > Normal Fetch

Operation - Memory

- Memory Operations
 - Load: read a data from the specified addr of the I-Mem
 - Store: write a data to the specified addr of the I-Mem
 - At most only one operation can be performed in a cycle
- Priority: why?
 - 1. load = store
 - 2. reset
 - 3. restart
 - 4. normal fetch